



AFTERMATH!

Book 1

BASIC RULES

for Role Playing Simulation

Designers: Bob Charrette
Paul Hume

U.S. COPYRIGHT NOTICE

Copyright © 1981 by Robert N. Charrette and Paul R. Hume. All rights to this book are reserved. No part of the book may be used or reproduced in any manner whatsoever without permission, except in the case of brief quotations embodied in critical articles or reviews.

Box, cover art and all illustrations are copyright © 1981 by Robert N. Charrette. For information regarding this game contact Fantasy Games Unlimited, Inc.; P.O. Box 182; Roslyn, N.Y. 11576

The designers will attempt to answer any questions regarding the game. Please type the question allowing space for the answer on the same sheet and enclose a stamped, self-addressed envelope. Send the letter in care of Fantasy Games Unlimited.



Fantasy Games Unlimited

CREDITS

Game Design: Paul Hume and Bob Charrette

Illustrations and Graphics: Bob Charrette

Typesetting: Liz Johnson, Dan Bress, Mat Roswurm, and Gryphon Graphics

Special Developmental Assistance: Jason Krause, Bill Colbert, Charlie Crickenberger, Peter Adams, James Polk, and Nick Buchholz
Playtesters: Jason Rein, Sean Morris, John McGuire, Uwe Behrmann, Mike Johnson, Tom Johnson, Rich Altman, and all the others who put up with us.

Special Thanks to Scott Bizar for having faith.

FOREWORD.....	4	MOVEMENT MODIFIERS CHART.....	17	HEALING DAMAGE.....	31
WHO'S WHO IN THE ROLE PLAYING GAME?.....	4	FORCED MARCH.....	17	IMMEDIATE FIRST AID.....	31
MEET THE GAME.....	5	THE FAST MARCH.....	17	RESTORATION OF LOST ATTRIBUTE POINTS.....	32
DEFINING THE CHARACTER.....	5	THE LONG MARCH.....	18	RESTORING A CHARACTER TO CONSCIOUSNESS.....	32
ATTRIBUTES.....	6	DETAILED ACTION TIME.....	18	INFECTION.....	32
ATTRIBUTE GROUP CHART.....	6	EFFECTS OF PRE-EMPTION & SURPRISE.....	18	OPTION.....	32
WIT.....	6	THE DETAILED ACTION TIME DISPLAY.....	18	DISEASES.....	32
WILL.....	7	THE CHARACTER ON THE DAT DISPLAY.....	18	DISEASE SYMPTOMS.....	32
STRENGTH.....	7	RESTRICTIONS AND DISTRACTIONS.....	19	DEALING WITH DISEASE.....	33
DEFTNESS.....	7	MOVEMENT.....	20	CRISIS POINT OF THE DISEASE.....	33
SPEED.....	7	CONTINUITY OF MOTION.....	21	DOCTORS AND DISEASE.....	34
HEALTH.....	7	STOPPING FORWARD MOTION.....	21	ANTIBIOTICS AND DISEASE.....	34
SAVING THROWS.....	7	STOPPING FORWARD MOTION TABLE.....	21	RECOVERY FROM DISEASE.....	34
TALENTS.....	8	CHARGING.....	21	OPTION IMMUNITY FROM DISEASE.....	34
PSYCHOLOGICAL PROFILE.....	8	MOVEMENT THROUGH OCCUPIED HEXES.....	21	POISONS.....	34
THE BASIC TALENTS.....	8	TREACHEROUS GROUND & MOVEMENT.....	21	EFFECTS OF POISONS.....	35
RAW TALENT USE.....	8	CLIMBING IN DETAILED ACTION TIME.....	21	TREATMENT OF POISONING.....	35
SPECIAL TALENT ABILITIES.....	8	CLIMBING MOVEMENT TABLE.....	21	ENCODING A POISON.....	35
ADDITIONAL TALENT BENEFITS.....	9	ENTERING THE ZONE OF INFLUENCE.....	22	CHARACTER IMPROVEMENT.....	36
ABILITIES.....	9	ENGAGED STATUS.....	22	IMPROVING SKILLS.....	36
FREELY IMPROVABLE SKILLS.....	9	PERFORMING ACTIONS.....	22	LEARNING-BY-DOING.....	36
DAMAGE RESISTANCE TOTAL.....	9	SIMPLE ACTIONS.....	22	STUDY AND SKILL IMPROVEMENT.....	36
COMBAT DODGE ABILITY.....	9	THE LAST SHOT OPTION.....	22	TABLE OF LEARNING RATE MODIFICATIONS.....	37
PHASES CONSUMED IN ACTION.....	9	FIRING WHILE MOVING.....	23	OPTION INITIAL SCORE IN NEW SKILL.....	37
ENCUMBRANCE CAPACITY.....	9	COMMUNICATION IN DAT.....	23	OPTION IMPROVEMENT OF ATTRIBUTES THROUGH LEARNING.....	37
OFF-HAND DEXTERITY.....	10	COMBAT PROCEDURE.....	23	OPTION INCREASE OF TALENTS THROUGH LEARNING.....	37
PHYSICAL CHARACTERISTICS.....	10	CONDUCTING AN ATTACK.....	23	IMPROVING ATTRIBUTE SCORES.....	38
RECOGNITION FACTOR.....	10	SITUATIONAL MODIFIERS.....	23	EFFECTS OF AGE ON ATTRIBUTES.....	38
SKILLS.....	10	THE "HOPELESS" ATTACK — ADJUSTED BCS LESS THAN 1.....	23	IMPROVING OFF-HAND DEXTERITY.....	38
FORMATS.....	11	ADJUSTED BCS EQUAL TO 1.....	23	QUANTIFYING THE ENVIRONMENT.....	38
BASIC CHANCE OF SUCCESS.....	11	ADJUSTED BCS GREATER THAN 1.....	23	BARRIERS.....	38
EFFECT NUMBERS.....	11	RESULTS OF A HIT.....	23	BARRIER FACTOR OF MATERIALS.....	38
AVERAGING SKILLS.....	11	MODIFICATIONS.....	24	DOORS AND LOCKS.....	38
RAW TALENT VERSUS TRAINED SKILL.....	11	DAMAGE POTENTIAL.....	24	SAMPLE LOCKING MECHANISMS.....	39
PREREQUISITES TO SKILLS.....	12	DAMAGE DONE.....	25	TOOLS AND THEIR USE.....	39
COMBAT SKILLS.....	12	SYSTEM SHOCK.....	25	FIRE AND ITS EFFECTS.....	39
POSITIONING DUE TO SKILL IN USE.....	12	TYPES OF DAMAGE.....	25	FIRE AND ARMOR MATERIALS.....	39
PRIMARY AND SECONDARY ATTACKS.....	12	IMPALEMENT.....	25	FIRE AND BARRIERS.....	40
WEAPONS DEFENSE ABILITY IN COMBAT.....	12	MISSILE SPECIAL EFFECTS.....	25	SMOKE AND ITS EFFECTS.....	40
AIM WITH A COMBAT SKILL.....	12	MISSILE SPECIAL EFFECTS TABLE D100 RESULT.....	26	ACID AND ITS EFFECTS.....	40
ALTERATIONS DUE TO AIM.....	12	STOPPING.....	26	ACID SPECIAL EFFECTS TABLE.....	40
CONTROL THROWS DURING COMBAT.....	13	CRITICAL HITS.....	26	SPLASHING RESULTS.....	40
THE THRUST IN COMBAT.....	13	CRITICAL MISSES.....	26	ON BEING A PLAYER.....	41
ENCUMBRANCE.....	13	GENERAL NOTES ON COMBAT PROCEDURE.....	27	READ THE GAME.....	41
DISTRIBUTION OF ENCUMBRANCE.....	13	OPTION "THE CLASH OF WEAPONS".....	27	BEING BORN.....	41
ENCUMBRANCE VALUE CHART.....	13	BASHING.....	28	GROWING UP.....	42
ENCUMBRANCE STATUS.....	14	OPTION SPECIAL EFFECT.....	28	GETTING YOUR HEAD ON.....	42
ACCESS TO STORED ITEMS.....	14	DELIBERATE KNOCKDOWN.....	28	BEING A HERO.....	42
PERSONAL MASS.....	15	GRAPPLING.....	28	ON BEING A GAMESMASTER.....	42
LOCATION AND ARMOR.....	15	FALLS IN DETAILED ACTION TIME.....	28	BEFORE PLAY.....	43
OPTION ENHANCED ARMOR VALUES.....	15	EFFECTS OF WATER ON MOVEMENT AND COMBAT.....	28	READING IT.....	43
ARMOR FORMATS.....	15	ON THE WATER.....	28	PLANNING THE CAMPAIGN.....	43
REINFORCING ARMOR.....	15	IN THE WATER.....	29	THE SCENARIO.....	43
LEATHER AND HIDES AS ARMOR.....	16	GOING UNDER.....	29	DURING PLAY.....	43
IMPROVISING ARMOR MATERIALS.....	16	FLOATING.....	29	ENJOYING THINGS.....	44
USE OF ARMOR TO PREVENT DAMAGE.....	16	UNDER THE WATER.....	29	RUNNING THE SESSION.....	44
AVERAGE ARMOR VALUE.....	16	OTHER NOTES ON WATER.....	29	THE OTHER GUYS (OR GIRLS).....	44
OPTION DESTRUCTION OF ARMOR.....	16	COMBAT ON A MOVING VEHICLE.....	29	AFTER PLAY.....	45
TIME AND MOVEMENT.....	16	THE CHARACTER AND HIS MOUNT.....	29	KEEPING YOUR BALANCE.....	45
STRATEGIC TIME SCALE.....	16	THE HORSE.....	30	IT'S A BIG, WIDE, WONDERFUL WORLD.....	45
TACTICAL TIME SCALE.....	16	HORSE AND RIDER IN DAT DISPLAY.....	30	HOUSECLEANING.....	45
DETAILED ACTION TIME SCALE.....	16	MOUNTED MOVEMENT THROUGH AN OCCUPIED HEX.....	30	L'ENVOI.....	45
REAL TIME SCALE.....	17	JUMPING ON HORSEBACK.....	30	APPENDIX 1.....	46
DOWN TIME SCALE.....	17	UNSEATING A RIDER.....	30	REACTION TABLE.....	46
COMBINING TIME SCALES.....	17	DAMAGE, HEALTH AND HEALING.....	31		
MOVEMENT IN TACTICAL OR STRATEGIC TRAVEL.....	17				

WHAT IS A FANTASY ROLE PLAYING GAME?

FOREWORD

You are reading the introduction to a rulebook for something called a Fantasy Role Playing Game. If you have never been involved in one of these Games before, it can seem confusing at first. The various rule books, the charts, maps, funny dice, just what are they for? How do you play this dumb game, anyway???

Role Playing Games are very different from almost every other type of game in the world. What we are going to examine here are the basics of how they are set up, played, and so on. In the rest of this book are articles giving more specific guidelines on how to play a Role Playing Game, with detailed illustrations of how the rules are applied.

FANTASY ROLE PLAYING GAME

First off, what do we mean by "Fantasy Role Playing Game?" Well, taken separately, the words themselves give us a clear picture of the term's meaning.

FANTASY: This implies that the Game deals with a world of high adventure, of heroes and villains, danger and treasure, brave warriors or explorers, cunning scientists, battle, victory and life, or the dusty death of defeat. The dull and workaday world, even on the cutthroat level of high finance or armies at war, is left behind. In a Fantasy Game, we are concerned with the individual hero, in an environment where great deeds must be performed daily.

Among the scores of Role Playing Games now on the market, rules can be found for Games set in milieus such as Sword and Sorcery adventure, interstellar travel and exploration, wild west "shoot-me-ups," the France of the Three Musketeers, Samurai Japan, and worlds that never have existed outside of the dreams of their designers. Almost any adventure setting desired can be found in a Role Playing Game somewhere. This broad scope is the reason the Role Playing Game hobby has grown so, since its inception some 10 years ago: it allows the players to actively take part in their fondest fictional adventures almost as if they were characters in their favorite book or film.

ROLE PLAYING: To be a player in a Role Playing Game, one plays a part just as an actor would. One has chosen a role in the Game-world and will operate in that environment as if he were really the character involved! This is the central concept in Role Playing Games—the Players do not move pieces around a game board, but react in the Game by describing and/or acting out the actions that the Characters they control are performing. In turn, everything that happens in the Game is described as if it were really happening! If, in the course of exploring a cave, the Characters find a dragon, Players are told this as if their eyes were actually beholding the beast.

There is a lot to say about the identification of the player (Joe Smith, gamer, who is playing this Game) and his Character (Roald the Bold, a brave warrior/wise magician/intrepid spaceman/vicious killer/etc.). Roald is a unique individual, with his own strengths and weaknesses, areas of expertise or ignorance, dreams, fears, and motivations. When Joe is playing, he must try to react to every situation as if he were Roald. We will be discussing the very special relationship between a player and his character in a later article in this book (On Being a Player, p.50).

GAME: The fantasy of the role-playing has limits placed upon it, and thus we define the last term in "Fantasy Role Playing Game." It is a Game, with rules governing what players (or their characters) can and cannot do. The rules give the methods for deciding how successful a Character is when he fights, or attempts to be acrobatic, or does anything requiring a particular amount of skill or knowledge. They give the values by which a player knows how strong his character is, or how smart. Rules also deal with Things: weapons, armor, tools, magical items or scientific wonders, vehicles — how they work in the game. For these Games are modeled on a particular sort of reality, and thus all the devices and ideas one is likely to meet in that reality should be handled in the rules, so that players know what they can do with them.

The person who decides what will happen in the Game, according to the rules and his own imagination, is called a Gamesmaster. Every Role Playing Game will have at least one of these individuals running it, for reasons set forth throughout these books.

So we have a definition of a Fantasy Role Playing Game as a Game, having definite rules and structure, setting up an atmosphere of high adventure in a fantasy world, where players control single characters by

playing out roles as those characters. That is the thumbnail view. Just how are people involved in this process? Read on.

WHO'S WHO IN THE ROLE PLAYING GAME?

There are several individuals involved in playing a Role Playing Game. Some are "real" (i.e. inhabitants of 20th Century Earth, having existence outside the Game), while others are not or at least do not exist outside the Game world.

THE GAMESMASTER

We have referred to this person before. Every Role Playing Game must have a Gamesmaster, also known as a Referee, Judge, etc. We will call him the Gamesmaster from now on.

In the last section, it was remarked that everything that happens in the Game is described to the Players as if it were really happening to them. Aha! Who do you think does the describing? Right—the Gamesmaster. Using the rules and a series of maps, notes, charts, and scenarios of his own design, the Gamesmaster is the one who lays out the Game before it is played. He is responsible for setting up everything that the Characters will encounter while playing, either in advance with loving detail, or at random during the course of play. When something develops in the course of the Game that the players should not know about, the Gamesmaster operates to keep it that way.

As for Role Playing, consider this: players need only act the parts of their individual characters. The Gamesmaster plays the role of every other being encountered in the Game. Some of these are not even human! In a typical, fast paced evening playing a Sword-and-Sorcery based Game, the Gamesmaster may be playing a wandering knight one moment and a raging dragon the next! The job of Gamesmaster is so important to Role Playing Games that a separate article later in this book will go into the concept of being a Gamesmaster in detail. (On Being a Gamesmaster, p. 52).

PLAYER

As is already obvious, players are the flesh and blood people who sit around and play a Role Playing Game. They are able to participate in the Game by pretending to be, and controlling the actions of, one or more Characters, individuals who "live" in the World where the Game takes place.

A player has designed a Character for himself, sometimes using random numbers and sometimes allocating an assigned number of points, to develop a clear model of what this "alter ego" is like. The physical and mental ability of the Character, what skills he will have studied and how much time he has given to each of them, all of these are under the player's control. When the character is actively adventuring in the Game, the player will decide when he fights and when he flees, and is, usually, in full control of the character's actions for better or worse.

So it is up to the player to know how the rules work for those things he has designed his character to do (combat, magic, medicine, whatever). It is also best if the player can "think with the character's head." This means, look at a situation in the Game and react properly for the Character according to his personality and cultural background. A character who has dedicated himself to one set of ideals will hardly act in a way contrary to those beliefs just because the situation offers some benefit for so doing. A crude peasant is unlikely to leave behind a purse of gold in order to retrieve a rare artwork from a treasure trove. The player should work out the behavior pattern for a character and keep to it as much as possible.

CHARACTERS

Unlike the Gamesmaster and players, characters do not really exist. Any entity (man, manlike being, intelligent creature, animal, self-aware computer, spirit, you-name-it) that takes an active part in the Game is a character. Those designed by or under the control of a player are called Player Characters. All the rest, usually under the control of the Gamesmaster, are called Non-Player-Characters.

Taken all together, the Characters make up the cast of this great big dramatic event called a Role Playing Game. Some will be heroic, champions of "good," saving damsels, distressed communities, etc., as a matter of course. Others will be villains, dealing in destruction and casual death. Most will be a combination of both, as different conditions arise in play.

THE CAMPAIGN

A Campaign is the particular version of a Role Playing Game as it is played by a given Gamesmaster and group of players. No two sets of gainers will play in exactly the same way. Characters, especially Player

Characters, are all different, and the adventures designed by one Gamesmaster will rarely resemble those set up by another.

It often amazes new gainers on the Role Playing scene that the same Game, identical rules, same setting, can be played in so many different ways. But this is part of that tremendous flexibility mentioned before, the ability of a good Role Playing Game to allow the participants to fulfill their special fantasy.

Of course, the main thrust in a Campaign is designed by the Gamesmaster. Using the rules, he will be the one to decide on the political climate of the countries in the Game-world, the locations of those mysterious sites where much adventure is to be found, as well as the specific kinds of risk and reward that exist there, the laws, customs, religion, and all the factors that go into the fully designed Campaign to give it a feeling or reality that makes for enjoyable play.

Some Campaigns are small in scope, perhaps limited to a single piece of territory with a base for Characters to operate from as they carry out raids on some huge maze-like place of danger and treasure. Other campaigns cover whole continents, or planets. Some (and this is not limited to science fiction Games by any means) comprise many worlds in the Campaign-universe. The size and complexity of a Campaign is limited only by the imagination and energy of the Gamesmaster and the desire of the players for new worlds to explore.

The Game, as such, is the rules package, the system for playing. It is the Campaign that is actually enjoyed by the group, a never-ending story of heroic adventure. The books you have in your hands are written to allow you to join in those epics. The only thing it takes is some of your time and a lot of your imagination. We hope you will enjoy playing this Game, in your unique Campaign, as much as we have enjoyed writing it for you.

MEET THE GAME

In this Game you will find the following components:

- The rulebooks, one of which you are reading now. They should be read carefully. Players (unless they are also acting as Gamesmaster in another campaign) should not read books specified as for the Gamesmaster. The Gamesmaster should, however, read all the material herein.
- The information in each book is laid out to cover the main areas which make the Game special: cultural data, social institutions of the Campaign world, special skills in the Game, etc. There are also separate charts for quick reference on things like combat and weapons, general rules, etc.
- An introductory scenario, a fully designed adventure, taking place in one possible type of Campaign setting. This is provided to give the Gamesmaster an example of how to set up a scenario, and to allow play to begin sooner, if the Gamesmaster and players are anxious to get going. Again, players should not read the scenario package. If they know everything that is going to happen before they start to play, the whole atmosphere of the Game will suffer.

THE DICE

This game uses two kinds of dice as detailed below. Such dice should be available in your local gaming store or can be ordered direct from Fantasy Games Unlimited.

TYPES OF DICE

6-Sided Die: Called a D6, This is an everyday cubical die, numbered from 1 to 6.

20-Sided Die: Called a D20. It is numbered from 1 to 10 (or 1 to 20) and can be used for many types of die rolls.

All the dice rolling called for in a Role Playing Game can be very confusing for new gainers. Consider this: no matter how detailed the set-up for a given action by the character may be, eventually the question must be answered, "Did he succeed?" In our Games (and most others) this is determined by calculating a chance of success expressed as a number, and then rolling a die. If the score from the die roll is such that the rules say it means success (based on the calculated number) then all goes well. If it falls into the range ascribed to failure by the rules, then whatever was being tried did not work. See the definition of "Basic Chance of Success" on p. 11.

Many different ranges of numbers are used for determining probabilities in this Game. The die rolls used are always expressed as follows: xDy In this expression the x stands for the number of dice thrown. The "y" stands for the type of dice used. 3 D6" means you should roll three 6-sided dice, and total their scores to get your result. "xDy+z" means that the number "z" should be added to the total of "xDy" to get the result.

These rules will sometimes call for odd "types" of dice to be rolled, such as D3, D10, D20, and D100. All these can be generated by using a 6-sided and a 20-sided die, as follows:

- **D3:** Roll a D6. Divide the number rolled in half, rounding fractions up. This gives a result from 1 to 3.
- **D6:** Roll a D6.
- **D10:** Roll a D20. Read a "0" result as "10."
- **D20:** Roll a D20. To get a result from 1 to 20, you will need to distinguish between the lower range (1-10) and the upper (11-20). One way is to color one set of faces of the die (0-9) different from the other (so that, for instance, a "red 3 would be read as a 3 and a "black 3 would be read as "13"). Another way is to roll a "control die" (D6) with the D20. A result of 1 -3 on the control die puts the D20 roll in the lowers range; a result of 4-6 puts it in the upper range.
- **D30:** Roll a D20 and a control die. If the control die is a 1-2, the D20 result is read as 1-10; if the control die is 3-4, the D20 result is read as 11-20; if the control die is 5-6, the D20 result is read as 21-30.
- **D100:** Roll two D20, to get a result of 1-100. Multiply the roll of one D20 by 10, and add to it the roll of the second D20 to get your result. Read a result of "00" as "100." D20s of different colors are very helpful for this.

The D100 is a very important type of roll. With D100 ("percentage") rolls, you can easily determine probabilities that may not be specified in the rules. If you feel there is a 60% chance of something happening, roll D100. A result of "60" or less means it happens. A higher result means it does not.

We will go into dice in more detail later on in this book and in the others. One important thing to keep in mind:

A die roll made to see if something happens means it did occur if the result is less than or equal to the needed number. A result greater than the needed number means it did not occur.

If dice are not available, an ordinary deck of cards and a little ingenuity can be used to generate the various random numbers used in the game.

SOME CONVENTIONS USED IN THE TEXT

Often in the text, the formula for calculating some number will be followed by "(up)," "(down)" or "(nearest)." This means that the result obtained should be rounded, respectively, up to, down to, or to the nearest whole number.

Some rules will be identified by the word OPTION in the heading of the section. These rules are not necessary to the play of the game. Some are intended to provide greater detail or more "realism" to the game; others simply allow variety in the way certain game situations can be handled. The players and the Gamesmaster should agree on which options will be used in their campaign.

Although the masculine pronoun is used in the general text, it is not intended to indicate the characters are assumed or required to be male.

READING THE RULES

When reading these rules, you should not try to absorb everything at once. Skim the rules once to get a general idea of the system. Then read them thoroughly. It is not necessary to be fully conversant with all the details in order to start to play. Diseases and poisons, for example, might not come into play for many game sessions.

Players should remember to avoid any section of the rules or game components not labeled as being for the players' use. You will spoil your own fun and that of the other players if you read the material that is intended for the Gamesmaster.

Gamesmasters are advised to be familiar with the sections of the rules that cover the things that they have planned for the current adventure. Careful planning of adventures will allow the Gamesmaster to introduce various portions of the rules gradually, as play progresses. This will allow you as Gamesmaster to familiarize yourself with the details of each section. It will also allow you to begin play more quickly.

As you read through these rules, don't be upset if a term is presented without immediate explanation. The game mechanics are interlocked in such a fashion that sometimes a term must be used prior to the section in which it is fully explained. Don't worry—it will eventually be explained. Also, don't be put off by our extensive use of abbreviations and acronyms. As you become familiar with the system, they will become second nature.

Good Gaming!

DEFINING THE CHARACTER

In order to determine just what a character can and cannot do, and how good he is at doing it, the character will be endowed with certain Attributes, Talents, Abilities and Skills. The character will also possess quantified

Physical Characteristics. These values allow the Gamesmaster to arbitrate game situations easily and consistently.

All characters have the same Attributes and Talents, but each character will have his own personal scores in each category. A character's Abilities are derived from his Attributes and, in some cases, from his Talents. Choice of a character's Skill's is, for the most part, left to the player. Initial scores in these Skills are based on the character's Attributes and Talents.

A character's numerical ratings in the above mentioned categories will be used to determine his success or failure when he attempts some action. The rating represents a number which the player, rolling the appropriate dice for the situation, must roll less than or equal to in order for his character to succeed. This basic number may be modified by the situation, in which case it is the modified number to which the dice roll is compared.

A character's Physical Characteristics are used primarily to add "color" to the character. If a player already "knows" what his character looks like, and it is agreeable to the Gamesmaster, he may choose ratings which fit his character as he conceives him.

All these ratings are entered on the Character Record Sheet (CRS) and kept handy for reference during play. This helps both the players and the Gamesmaster; the players have a better idea of their chances of success, and they can supply the Gamesmaster with the numbers he needs to determine the results of actions as they occur. We recommend that entries on the CRS be made in pencil, since values may alter during the course of play.

ATTRIBUTES

Attributes are the basic mental and physical components that make up the character. They define such things as how hard he hits, how fast he runs, how well he retains what he learns, how well he resists disease, and many other things. These rules use six Attributes: Wit (WT), Will (WL), Strength (STR), Deftness (DFT), Speed (SPD) and Health (HLH). The first two are Mental Attributes; the last four are Physical Attributes.

Normal human ratings range from 1 to 40. A character with a rating of 1 in an Attribute is severely handicapped in the areas that Attribute governs. With a rating of 40 he is, in that regard, a peak specimen of human development. The mythical average man would have a score of 10 to 12. A character with a rating less than 1 in an Attribute is totally non-functional in that area. A rating greater than 40 is not possible for a human without mechanical, chemical or supernatural aid.

When creating a character, a player will receive a certain number of points to allocate among the character's Attributes. He may distribute them among the six Attributes as he likes, so long as the character has no rating less than 1 or greater than 40 in any Attribute. He should then enter these ratings on his Character Record Sheet, in the Allocated column of the Attributes section.

As play proceeds, a character may improve the initial ratings of his Attributes, or suffer permanent Attribute losses. When this occurs, the player should enter the new rating in the Permanent column of the Attributes section. Otherwise, the Permanent is the same as the Allocated rating. For details on improving Attributes, see Character Improvement, p. 43.

During play, a character may experience a temporary alteration of an Attribute rating. The new, temporary rating should be entered on the Character Record Sheet, in the Effective column of the Attribute section. Otherwise, the Effective rating is the same as the Permanent rating. If any ratings were lowered by wounds, disease or other damage, the player can see how many points must be healed to restore his character's ratings to Permanent level. See Healing Attributes on page 37.

Ranges of Attribute ratings are arranged in Groups, as listed below. The Effect Die noted for each Group represents the effectiveness of proper application by a character of a Skill governed by that Attribute. Attribute Groups are also used to calculate other values relating to characters. These will be dealt with as they arise.

ATTRIBUTE GROUP CHART

Attribute	0	1-4	5-14	15-24	25-34	35-44	45-54	55-64	65-74
Rating									
Group Number	0	1	2	3	4	5	6	7	8
Effect Die	None	1D3	1D6	1D10	2D6	2D10	2D10+	2D10+	2D10+

TEMPORARY ALTERATION OF ATTRIBUTES

Various situations that may arise in play call for temporary reductions, expressed in percentages, of a character's Attributes. This may be due to wounds, encumbrance, poisons, drugs or many other factors. Such reductions are usually made in two steps: 25 percent and 50 percent. Subtract the required percentage from the character's current Effective rating in the Attribute, to get the new Effective rating.

When a character moves from a state of lesser reduction to a greater reduction, the procedure is somewhat different. Subtract the lesser percentage from the greater percentage, and use the result as a percentage reduction.

For example, a character who is Wounded (25% reduction of Deftness and Speed Attributes) becomes Seriously Wounded (50% reduction of both Attributes). In this case subtract 25% (50%-25%) from the current (Wounded) Attribute rating to obtain the new Effective rating.

Of course, if an unwounded character becomes Seriously Wounded in one step, simply apply the 50% reduction.

If a reduction in Basic Chance of Success (BCS) is to be applied to a character who has already suffered some reduction in BCS, apply the new reduction directly.

Various categories of situations which can cause temporary alterations of Attribute ratings are treated independently. Within a given category, follow the guidelines noted above. Details are given later in the rules.

WIT

The Wit Attribute is not a measure of the character's intelligence. The native "intelligence" of a character depends on that of the player. The player may decide that his character is smart or dumb, as he likes. Wit, however, has an important effect on the character's ability to learn. Wit is also a measure of the character's ability to discover "Hidden Things" and, in general, to observe and interpret things that are out of the ordinary.

LEARNING RATE

A character's Learning Rate is the base used to determine how much he may add to a Skill rating as a result of a learning session. Learning Rate is equal to the character's Wit Group. The specifics of learning are dealt with under Character Improvement, page 43.

DETECTING HIDDEN THINGS

When there is a Hidden Thing to discover, the Gamesmaster secretly rolls 1D20 and asks the players whose characters are in a position to discover the Hidden Thing for their Critical Saving Throw scores. The Gamesmaster may modify the score needed by a number related to the difficulty of discovering the Hidden Thing. Any character whose modified score equals or exceeds the Gamesmaster's die roll will have spotted the Hidden Thing. The Gamesmaster can then inform those players of what they have found and they may or may not have their characters reveal this knowledge to other characters who are present.

The die roll is made secretly so that the players will remain uncertain: is there nothing there, or is there something they failed to discover? The Gamesmaster should go through this procedure as a deception, at least as often as he uses it for actual Hidden Things.

If the secret die roll is a 20, the Gamesmaster should inform some or all of the players of the discovery of a false "Hidden Thing." The Gamesmaster is urged to be creative, and have fun, when his players discover things that are not there.

The adventurers (characters) are exploring a ruined castle and have gathered in what was once the study. The players decide to have their characters search the room for hidden compartments (there actually is one to be found, as the Gamesmaster knows). The Gamesmaster rolls 1D20, with a result of 20. Thinking quickly, he picks the number 3, and asks the players if any of their characters have a Wit Critical Saving Throw of 3 or higher. Several do (as the Gamesmaster already knew). He informs those players that their characters have discovered signs of a hidden compartment in a desk.

The players are now set up: they will probably waste quite a bit of time trying to force entry into the "hidden compartment." The Gamesmaster may let them try everything they can think of, until they give up in disgust, or he may allow an arbitrary length of time to pass—say five minutes—then tell the players they were wrong.

Undaunted, the characters continue to search the room. The Gamesmaster again rolls 1D20. This time the result is a 5. One of the characters has a Wit Critical Saving Throw of 5, and discovers an actual

hidden compartment in a bookcase. Since the character with the Wit Critical Saving Throw of 5 had the highest Wit rating of the characters present, a secret die roll of 6 by the Gamesmaster would have meant that none of the characters could have discovered the hidden compartment.

WILL

Will is a measure of the strength of a character's mind. This includes the character's drive and determination, and the strength of mental resistance his mind is capable of putting up. Things that can attack the Will of a character include the strange mental powers of mutants, magical powers, and the mind-numbing effects of certain chemical compounds. In general, Will can be regarded as the Mental equivalent of the Health Attribute.

STRENGTH

Strength is a measure of the sheer physical power of the character. This Attribute is particularly important in determining with how much force he can wield a hand-held weapon. It also affects how much recoil from a gunpowder weapon he can sustain without suffering loss to his BCS in firing.

WEAPON DAMAGE

The character's Strength Group will determine the Effect Die to be rolled (see chart, p. 4). Since weapons are treated as mechanical devices, the result of the Effect Die Roll will be multiplied by the weapon's Damage Multiplier to yield the Damage Potential of the character's attack, if successful. Naturally, a character with a high Strength Group will tend to do more damage when he makes a successful attack.

WEAPONS USE

A character's Strength Group determines what kinds of weapons he may use when attacking with a Hand-to-Hand Combat Skill. All Hand-to-Hand weapons are rated by the Strength Group required to use them without difficulty. A character may freely use any Hand-to-Hand weapon rated equal to or less than his Strength Group. A character may not use a weapon whose rating exceeds his Strength Group by 2 or more.

If a character uses a weapon with a rating 1 greater than his Strength Group, he must use the Effect Die listed for the Group 1 lower than his actual Group.

If a weapon noted as a 1-1/2H (a "hand-and-a-half" type weapon) or 2H (a two-handed weapon) is used one-handed, its rating goes up by 1. That is, a character would need to be in a Strength Group 1 higher to use such a weapon one-handed than he would to use it normally.

When a character is using the Two Weapon Combat Skill, and the rating of one weapon exceeds, or that of both equals, his Strength Group, then the effective rating of each weapon is increased by 1.

The penalties noted in the preceding two paragraphs are cumulative. Note that a character using the Two Weapon Combat Skill may find, due to cumulative increases in weapon ratings, that he is totally unable to use one weapon.

Jo the Strong is a character with a Strength of 35. He is thus in Strength Group 5, and his normal Effect Die will be 2D10. He wishes to use a two-handed sword with a Strength Rating of 5. He may do so freely, if he wields it with two hands. If he tries to swing it one-handed, its effective Strength Rating is raised to 6. Jo can use it this way, but his Effect Die will be that of Strength Group 4 or 2D6.

If Jo's Strength were less than 31 he would be in a Strength Group lower than 5, and he would be completely unable to use the sword one-handed.

Sal of the Sharp Blade prefers to fight with a weapon in either hand. She has a Strength of 15, putting her in Strength Group 3. If she tries to use two weapons, each with a Strength Rating of 3, each weapon would have its effective Strength Rating raised to 4. She would be able to wield them, but her Effect Die would be that of Strength Group 2 — 1D6.

If she uses one weapon with a rating of 3 and one with a rating of 2, she will incur no penalties, and use her normal Effect Die, 1D10.

If she foolishly tries to use a 1-1/2H weapon with a rating of 3 in one hand and a weapon with a rating of 2 in the other, the latter will not be affected, but the former will have its rating increased by 1 for being used with one hand, and again increased by 1 for being used with one hand, and again by 1 because it then exceeds her Strength Group. This gives the weapon a rating of 5, 2 greater than her Strength Group. She discovers that she cannot use the 1-1/2H weapon at all, when using the Two Weapon Combat Skill.

DEFTNESS

Deftness is a measure of a character's manual dexterity and reaction time. It is used to determine how often a character may act in a given situation, and whether he can complete a task requiring dexterity.

MAXIMUM NUMBER OF ACTIONS

The Maximum Number of Actions (MNA) refers to the number of Actions (see Detailed Action Time, p 20) that the character may initiate and complete in a Combat Turn.

Maximum Number of Actions equals Deftness Group.

SPEED

Speed is a measure of a character's agility and rapidity of action. It is used to determine when a character may act in a given situation. Speed also determines the character's rate of travel.

BASE ACTION PHASE

The Base Action Phase is the first point in a Combat Turn in which a character may initiate an Action. The Base Action Phase (BAP) is equal to half the character's Speed (down).

HEALTH

Health is a measure of a character's constitution, resistance to disease and recuperative powers.

HEALING RATE

Healing Rate is the basic amount of damage, expressed in points, that a character can heal in a period of time. Applications of Healing Rate are explained in Damage, Health and Healing, p 36.

Healing Rate equals Health Group.

SAVING THROWS

When a player wants his character to perform an action which lies in the province of an Attribute, or when the rules call for it, the Gamesmaster will ask the player to make a Saving Throw (ST). This may be an Attribute Saving Throw (AST) or a Critical Saving Throw (CST). The CST is used when the action to be attempted is very difficult. The number needed for a successful Saving Throw should be calculated for each Attribute, and entered on the Character Record Sheet.

Saving Throw numbers are always calculated using the character's effective Attribute rating.

Attribute Saving Throw (AST) equals Effective Attribute rating/2 (down)

Critical Saving Throw (CST) equals Effective Attribute rating/3 (nearest)

Unless the rules specify otherwise (and even then, if he chooses) the choice of requiring an AST or a CST is left to the Gamesmaster. He should base his decision on the difficulty of the situation or the action attempted. On occasion, at the Gamesmaster's discretion, modifiers can be added to or subtracted from the number needed for a successful Saving Throw.

To determine if a Saving Throw is successful, the player must calculate the number needed, add or subtract any modifiers, and roll 1D20. If the result is greater than the number needed, the character has failed his Saving Throw and must face the consequences.

A die roll of 1 signifies greater success than was hoped for, and a roll of 20 signifies a disastrous failure. The exact results of such "critical" success or failure are left to the creativity of the Gamesmaster.

When characters are making Saving Throws in particularly stressful situations, the Gamesmaster may levy a "charge" in subdual points (see p. 29) for each attempt, whether or not it succeeds. This prevents characters from throwing themselves at locked doors all day—eventually they will batter themselves senseless, if the door is stronger than they can overcome, and even eventual success would have its price. A die roll of 20 would call for double subdual damage, or perhaps for a point of lethal damage in addition to the subdual damage. The Gamesmaster must decide whether to exact such penalties, and to what extent.

Elsie Smith, survivor of the Ruin, is fleeing for her life through rumbled streets. She is desperate. The Gamesmaster tells Elsie's player to make a Wit CST. The roll succeeds. The Gamesmaster announces that Elsie has spotted a fire escape in an alley. The player has Elsie move into the alley and make a jump for the ladder. The Gamesmaster requires a Deftness AST for Elsie to make a successful grab at it. Elsie's player rolls a 1 on the D20. The Gamesmaster decides that Elsie has not only grabbed the ladder but has swung her body weight in such a way that the rusted ladder has come free and Elsie may climb it on the next Combat Turn. If non-critical success

had been indicated by the die roll, the Gamesmaster might have required Elsie's player to roll a Strength AST to unstick the rusty ladder.

As Elsie climbs the fire escape, she hears the groan of tortured metal. The player, realizing that the fire escape may collapse, says that Elsie is hastening to find a way off the fire escape. Since the player recognized the danger, the Gamesmaster requires a Speed AST (rather than a CST) for Elsie to clear the collapsing fire escape. Again the die roll is in Elsie's favor, and she enters the building just as the fire escape crashed down into a pile of twisted metal.

Elsie lands in a heap as she leaps through the window. Dust billows about her as she rises in the deserted room. The Gamesmaster tells Elsie's player to make a Health AST. Fearful that Elsie may have encountered a dangerous biological agent, the player makes the die roll. This time the result is greater than the success score for Elsie's Saving Throw. The Gamesmaster thanks the player and asks for Elsie's next actions. This request for a Saving Throw was a deception—there is no dangerous biological agent in the room. The Gamesmaster is following the Golden Rule: Keep em guessing. The players never feel entirely safe, never know when danger is lurking around the corner.

Ignoring the clue (the unsound fire escape) to the less than perfect structural integrity of the building, Elsie enters the corridor outside the room and runs toward the stairwell. The Gamesmaster, having previously determined that the floor of this corridor would give way under a person's weight, announces that Elsie has fallen through. Since she had no warning, the Gamesmaster requires a Speed CST, and because she was moving at full speed, subtracts 2 from the score needed to succeed. Not surprisingly, the die roll indicates that Elsie failed to grab onto anything that could have arrested her fall. The Gamesmaster requires a Health AST for Elsie to remain conscious when she hits the floor below (adding 1 to the score needed, since she will land in a large pile of windblown leaves). Elsie's luck takes a turn for the better; she is conscious. A quick check for damage done by the fall shows that Elsie has suffered 4 points of Subdual Damage, with no critical effects.

OPTION An alternate method for modifying difficulty:

The Gamesmaster may assign a die with a greater or lesser range than 1D20 to be used for the Saving Throw, instead of modifying the number needed for success. If he wishes to increase difficulty, for example, he might require the Saving Throw to be rolled on 1D30 instead of 1D20.

TALENTS

Talents are a measure of the character's aptitude and raw ability in the areas specified. Talents can modify the character's Learning Rate and enable him to learn by the successful application of his Skills. For specifics on these functions, see Character Improvement, p. 43.

A Talent has a maximum score of 20 and no minimum natural score. A score of less than 1 indicates that the character has no native aptitude at all in that area. A score greater than 10 indicates significant aptitude.

PSYCHOLOGICAL PROFILE

Each character will have a "psychological profile" when he is created. The method is detailed in Book 2. This profile gives the base starting values for the character in each Talent. The player will then roll 2D6 + 15. The result is a number of points which he may allocate among the various Talents. No initial score may be lowered in order to add points to another Talent. No final score may exceed 20. Any Talent score may be left at its initial value, even if that value is negative.

John Smith, player, is creating a character. He wishes the character to be a fighter, who is at home in the outdoors. After determining his character's psychological profile, he finds that the character's Talent scores are: Charismatic -2; Combative -2; Communicative +1; Esthetic 0; Mechanical +1; Natural +2; Scientific +1.

John rolls 2D6 + 15. The roll is 8, so he has 23 points to allocate among his character's Talents.

In keeping with his plans for the character, he adds 13 points to Combative to raise it to +11, and 9 points to Natural to raise it to +1 1 as well. He adds the remaining point to Esthetic, raising it to 1. This will allow the character to Learn-by-doing with a Skill whose Governing Talent is Esthetic.

John's character, whom he now nicknames "The Hunter," has some special abilities. Due to his Combative Talent score, he has an 11% chance to gauge his opponent's skill with a Weapon. He can also estimate compass direction with an 11% chance of success, because of his Natural Talent

score. Because of the nature of the Combative Talent, The Hunter will have a base BCS of 2 (11Divided by 6, down) in any weapon form.

THE BASIC TALENTS

The seven basic Talents, and the general areas governed by each are:

Charismatic:	Basic persuasiveness, and the ability to lead others.
Combative:	Aggressiveness, the "will to win," and raw fighting ability.
Communicative:	Facility with languages, and the general ability to communicate an idea.
Esthetic:	Appreciation and performance of artistic endeavors.
Mechanical:	Affinity for technology and its products.
Natural:	Affinity for the natural environment.
Scientific:	Capacity for reasoned analysis, perception of cause and effect.

RAW TALENT USE

In the absence of a character trained in a required Skill, the Gamesmaster may allow the character with the highest score in that Skill's Governing Talent to try to use the Skill. His score in the Governing Talent is used to determine his Basic Chance of Success (BCS), The BCS, of course, may be modified according to the difficulty of the situation. If the required Skill has a Prerequisite Skill in which the character has no score, then his Governing Talent score is effectively halved for purposes of computing the BCS. The Gamesmaster should require a character using raw Talent to perform a task to use more game time than would a character using the appropriate Skill. If the character succeeds by using raw Talent, he is then able to learn from it in the usual fashion.

Situations may arise in which the Gamesmaster decides that a required Saving Throw is more in the province of a Talent than of an Attribute. In such a case the player should roll 1D20, a roll less than or equal to his character's score in the appropriate Talent indicating success. As usual, a roll of 20 denotes failure, even if the character's Talent score is 20.

Quill, a medical technician, is trapped in a decompressing space station. All doors have been sealed, and he is on the wrong side of the door to the escape craft hanger. He has no electronic skills at all, and must short circuit the door's mechanism in order to escape. However, he does have a BCS of 18 in High Technology Use Skill, and a Mechanical Talent of 15. The Gamesmaster decrees that Quill can open the door if he makes both a successful roll for his High Technology Use Skill and a raw Talent roll using his Mechanical Talent. The player rolls 5 on 1D20—Quill is halfway there. He has popped the panel over the wires and identified the ones he thinks control the door. The player now rolls 1D20 against his raw Mechanical Talent. The result is 3, and he breathes a sigh of relief. But the Gamesmaster has decided that the attempt will cause Quill to be hit with 2 units of electrical charge. As Quill crosses the wires, sparks fly and he is knocked back across the chamber. Fortunately, he was wearing insulated gloves, which eliminate one of the units of charge. The Gamesmaster checks for damage, rolling 4 on 1D10. He tells the player that Quill has taken 4 points of Subdual Damage. Quill picks himself up, shakes his head to clear it, and bolts through the open door to the escape craft.

SPECIAL TALENT ABILITIES

When a character has a Talent score greater than 10, he is assumed to have a Special Talent Ability related to that Talent. In general, his percentage chance to use the special ability is equal to his score in the Talent. Only one attempt to use a special ability may be made in any one situation.

As usual, a die roll in the range 96-00 denotes failure, and probably an unexpected backfiring of the attempt.

The special abilities associated with each Talent are:

Charismatic:	The character may add his Talent score divided by 5 (down) to NPC reaction rolls, provided he can communicate with the NPC he is trying to influence; or he may choose to subtract from the reaction roll. Note that this special ability does not require a D100 roll.
Combative:	The character may attempt to "gauge" his opponent—discover his opponent's Skill score with the weapon he is using. He may make only one attempt per opponent.
Communicative:	The character may attempt to pick up the general sense of something spoken in a language he does not understand. Alternatively, he may attempt to convey a general concept to another character or NPC. Note that specific detail cannot be conveyed across a language barrier.

- Esthetic:** The character may attempt to “compose” on the spot. It must be in an artistic form that he knows—that is, he must have a score in the Skill governing that form.
- Mechanical:** The character may attempt to estimate the mechanical complexity of a technological artifact (e.g. a lock) or the structural soundness of a construct (e.g. a door).
- Natural:** The character may attempt to use his sense of direction to estimate compass directions, or avoid becoming lost. Note that once a character has failed in such an attempt, he will be unable to do it successfully until he has reoriented himself by some indicator such as a compass, the sun or a familiar star field.
- Scientific:** The character has an analytical ability with which he may attempt to solve conceptual problems such as codes and riddles.

If a character qualifies for special abilities in more than one area he will receive all appropriate abilities. In addition, some Talents in combination yield additional abilities. The percent chance of success for these combination abilities is the average of the Talent scores in the areas in question. Remember that both of the Talents involved must have a score that exceeds 10.

The Charismatic Talent interacts with three of the other Talents to yield combination ability. These Talents are Communicative, Esthetic and Natural. The effects of the combination ability for each are listed below:

Charismatic plus

Communicative: The character, upon successfully communicating with the personage being swayed, will get him to react as desired. Note: This represents persuasive argument. It is not a form of mind control. A character could only be persuaded to suicide if he were already in a self-destructive frame of mind.

Esthetic: The character, upon successfully performing with his artistic Skill, can implant simple ideas, emotions and sentiments in those who are affected by the artist's work.

Natural: The character is responsive to animals. He may calm or excite them and get them to do simple things within their limitations. Note: This does not allow the character to stop an animal's attack once begun, although he might dissuade it from attacking as long as none harm it. Also he cannot communicate with animals as if they had human intelligence.

ADDITIONAL TALENT BENEFITS

Some of the Talents have additional benefits. These are peculiar to the Talent involved and any character with a positive score receives such benefits. The specifics are listed below:

Combative: The character may use his Talent score as a Skill score in any Combat Skill in which his score is less than his Talent score. From this a Basic Chance of Success may be calculated and to the Basic Chance modifications due to the situation and the weapons in use will be added. Note: This may not be used with averaging Combat Skills if at least one of the scores to be averaged exceeds the Talent score.

Mechanical: The character may substitute his Talent as a Basic Chance of Success for the Skill of Technology Use. This Skill is basic familiarity with tools, devices and simple machines.

Scientific: The character may use his Talent score/5, down as a Basic Chance of Success modification, positive or negative at whim, when dealing with games of “chance” which involves shifting odds, such as card games.

ABILITIES

Each character has certain Abilities which are derived from a combination of his Attributes. They are aspects of quantifying the character before play begins. Once the values have been calculated, they should be entered in the proper place on the Character Record Sheet. Each of these Abilities will be introduced and explained below.

If a character's Ability values should be altered in the middle of a turn in Detailed Action Time, the new values will not be applied until the bookkeeping phase of that turn.

FREELY IMPROVABLE SKILLS

A character may designate a number of Skills equal to the combined score of his current Wit and Will as Freely Improvable Skills. Whenever a character is studying a Skill which is not one of his designated Freely Improvable Skills, he is suffering a Hindrance to learning which will reduce the number of points he may add to his score as a result of that Study period.

The Skills in which a character receives initial scores are not necessarily counted against this number. If the player doubles the initial score of a character's Skill, that Skill is assumed to be one of the character's Freely Improvable Skills. If more Skills than are “allowed” by the quota are doubled, the player may decide which are to be considered Freely Improvable Skills.

Skills will be added to the character's quota as they are studied. It is not permissible, before the character has reached his quota, to claim a new Skill, or a Skill which the character improves for the first time, is not a Freely Improvable Skill, It is to be counted against the quota. All Freely Improvable Skills should be marked as such on the Character Record Sheet by underlining, circling or some other method agreeable to the players and the Gamesmaster.

Should a character's Wit or Will change permanently, his Freely Improvable Skills quota will alter to reflect the new values, If it goes up, the character will add the next Skills studied to the list of Freely Improvable Skills. If it goes down, the player may choose which Skills will no longer be considered Freely Improvable. Should his total subsequently go up, the character will regain those removed from the list before designating other Skills as Freely Improvable.

DAMAGE RESISTANCE TOTAL

The Damage Resistance Total (DRT) of a character is equal to his Permanent Health plus ½ Permanent Strength plus ½ Permanent Will. This is a measure of how much damage, inflicted upon him by chance or his enemies, he is able to take before he collapses.

Damage done to the character is measured in “points.” Any points of damage the character receives are totaled together to give a current damage total. When the current total of damage points exceeds one half of the Damage Resistance Total, the character is considered Wounded. He will suffer a 25% loss to Deftness and Speed. This will change the effective values of those two Attributes and alter such things as the character's Base Action Phase, Maximum number of Actions, Combat Dodge Ability and Phases Consumed in Action. Additionally, the character will suffer a -2 modification to all Basic Chances of Success. When the current total of damage points exceeds 75% of the Damage Resistance Total, the character is considered Seriously Wounded. He suffers a 50% loss to Deftness and Speed and suffers the attendant problems. He also receives a -4 modification to all Basic Chances of Success. These modifications remain in force until the character is healed of the damage taken. See Health and Healing on page 36.

COMBAT DODGE ABILITY

The Combat Dodge Ability (CDA) is the character's capacity to move his body out of harm's way while in combat. This is his basic defense factor. It is subtracted from his opponent's Basic Chance of Success. The base value of the Combat Dodge Ability is given below although the actual value may vary according to the situation. (See the Target Movement Rules in Book 2.)

Combat Dodge Ability equals

(Effective Deftness plus Effective Speed)/20, nearest.

PHASES CONSUMED IN ACTION

This is a measure of how long, in relative terms, that it takes a character to perform a simple function. The specific applications of this value are dealt with in the section on Detailed Action Time on page 20.

Phases Consumed in Action equals

Base Action Phase/Maximum Number of Actions, down

ENCUMBRANCE CAPACITY

The Encumbrance Capacity (ENC CAP) is a measure of how much the character can wear, carry and use without getting in his own way. A character whose Encumbrance total is less than or equal to his CAP/2, nearest is considered to be Unencumbered and receives no modifications.

A character whose Encumbrance Total is greater than CAP/2 and less than or equal to (3 x ENC CAP)/4 nearest, is considered to be Partially Encumbered. This character will have his effective Deftness and Speed

lowered by 25% and will suffer a Basic Chance of Success modification of -1 to all endeavors requiring physical exertion.

A character whose Encumbrance Total is greater than (3 x ENC CAP)/4 is considered to be Fully Encumbered. In this state, effective Deftness and Speed will be lowered by 50% and he will have a modification of -2 instead of -1 for physical endeavors.

A character may not have an Encumbrance total that exceeds his Encumbrance Capacity.

A character may lift up to 150% of his Encumbrance Capacity for a very short time only. A Strength Critical Saving Throw which is required to be made on each Combat Turn is a good way of determining how long a character can lift such a weight. The Gamesmaster is urged to levy subdual points for actions of this kind. One point per turn for each 10% over the character's Encumbrance Capacity is a good scale.

A character may shift, without lifting, an Encumbrance Total equal to twice his Encumbrance Capacity. It is suggested that this kind of action be subject to the same penalties and limitations as the rule for lifting above.

The concepts of Encumbrance are dealt with in the section on page 14.

Encumbrance Capacity equals

3 plus Strength Group plus Deftness Group.

These values are taken from the Permanent values of the character's Attributes.

OFF-HAND DEXTERITY

Characters are assumed to favor one hand with regard to manual dexterity. For convenience, the Gamesmaster may wish to assume that the character's favored hand is the same as the player's favored hand, unless the player specifies otherwise before the character enters play. All Skills using the hands will be assumed to be using the favored hand in their primary applications. Should the character be brought to the point where he must attempt to utilize such a Skill and his favored hand is disabled or absent, he will have to average his Basic Chance of Success in that Skill with his Off-hand Dexterity score. The Off-hand Dexterity score will never raise the Basic Chance of Success above the value the character would have if he were performing normally with the Skill.

Off-hand Dexterity can be increased as detailed in the section on Character Improvement on page 43. The initial value is based on the character's Attributes and a random factor. This value is calculated from the Allocated Attribute scores and will not be affected by changing the Attribute scores.

Off-hand Dexterity equals

(Wit plus Will plus Deftness)/6, nearest plus 2D3

Kelson is left-handed and has a Pistol Combat Skill with a BCS of 12. He has been wounded in the left arm and cannot use it. Groggily, he picks up his pistol with his right hand. Fortunately, he has increased his Off-hand Dexterity to 17. Averaging his Pistol BCS and his Off-hand Dexterity score will yield 14.5. This is rounded down to 14. Since the Offhand Dexterity score cannot increase the BCS of the Skill being used, it is reduced to 12 which happens to be his normal base BCS.

If Kelson's scores had been reversed (his Pistol BCS 17 and his Off-hand Dexterity score 12), averaging would have yielded 14.5 which would have been rounded to 14 to give the base BCS for using the pistol with his off-hand.

PERSONAL ENCUMBRANCE CHART

SIZE	BULK						
	Very Low	Low	Below Average	Average	Above Average	High	Very High
Very Low	3.0	3.1	3.3	3.5	3.7	3.9	4.0
Low	3.1	3.3	3.5	3.7	3.9	4.0	4.1
Below Average	3.3	3.5	3.7	3.9	4.0	4.1	4.3
Average	3.5	3.7	3.9	4.0	4.1	4.3	4.5
Above Average	3.7	3.9	4.0	4.1	4.3	4.5	4.7
High	3.9	4.0	4.1	4.3	4.5	4.7	4.9
Very High	4.0	4.1	4.3	4.5	4.7	4.9	5.0

PHYSICAL CHARACTERISTICS

The quantification of the physical aspects of the character is on a completely random basis, unlike the Attributes, Talents and Abilities. As a result, any player who can present a convincing case to the Gamesmaster as to why the character he is playing should have certain specified statistics should be allowed to use those statistics rather than rolling randomly to determine them.

For Size, Bulk and Looks, roll separately using 1D100. The resulting number and description from the Physical Aspects Chart should be recorded on the Character Record Sheet.

The descriptions for Size and Bulk should be cross-indexed on the Personal Encumbrance Table and the number found there entered as the character's Personal Encumbrance.

The Physical Characteristics of Size and Bulk are important in determining if the character can wear scrounged clothing or scavenged armor. The Personal Encumbrance is used in calculations for Bash attacks and other things where mass is important.

RECOGNITION FACTOR

The Recognition Factor is used by the Gamesmaster to determine if the Player Characters are recognized, for good or ill, by the Non-Player Characters with whom they interact. The Player Character's base factor is the sum of the Recognition factors he receives for Size, Bulk and Looks. This is modified by the Gamesmaster for such things as distinctive clothing, identifying marks, reputation and whether the character announces his name.

PHYSICAL ASPECTS CHART

Die Roll (1D100)	Size & Bulk	Description Looks	Recognition Value	Equivalent Height	Average Weight for Height
01	Very Low	Ugly	3	under 5'4"	71-100 lb.
02-05	Low	Homely	2	5'4"-5'5"	101-120 lb.
06-26	Below Average	Mediocre	1	5'6"-5'7"	121 -140 lb.
27-74	Average	Average	0	5'8"-5'10"	141-160 lb.
75-95	Above Average	Above Average	1	5'11"-6'	161-180 lb.
96-99	High	Comely	2	6'1"-6'2"	181-200 lb.
100	Very High	Handsome	3	over 6'2"	201 -230 lb.

To find weight for a character with non-average Bulk move a number of steps, up or down, as appropriate, equal to the Recognition value for Bulk.

SKILLS

A major aspect in the quantification of the character is the concept of Skills. Functions of import to the game that do not involve the simple exercise of body or mind by the character are governed by Skills. The Skill score is a quantification of the character's expertise and ability in a given area. The character's score in a Skill represents his basic competency in the area or areas covered by the Skill. This is hard-won, ingrained knowledge and is not to be gained from casual instruction or undisciplined study.

If a character does not have the Skill required to perform a function, he is usually thrown back on his Talents or Attributes. These are a poor substitute for rigorously acquired expertise. Though a character's initial scores in the Skills with which he begins the game are based on appropriate Attributes and Talents, he can improve the scores by diligent study and significant, successful application of those Skills.

Certain Skills cover things that anyone can do. This does not mean that a character who does not have a score in that Skill cannot perform in that area. It does mean that when the situation is such that a character has difficulty performing in the area governed by the Skill, a character without a score in the Skill will almost certainly fail. For example, anyone can ride a horse, but a character who does not have a score in Beast Riding Skill will probably fall off if the horse gallops and will almost certainly fall off if the beast bucks.

The very choice of initial Skills often defines the character's past and his chances in the future. In this fashion, the player may tailor his character to suit whatever conceptions he has about that character.

Skills, as presented in Book 2, are given in a particular format. The name of the Skill is followed by the calculation for the initial score. The first Attribute in the formula is the Governing Attribute and the first Talent is the Governing Talent. These come into play with regard to character improvement. If the Skill is a Combat Skill, the Positioning of a character using the Skill is placed in parentheses after the name of the Skill. The initial score formula is followed by a number indicating the Format of the Skill. If the Skill requires any prerequisite Skills, they are listed in parentheses under the Skill name. A description and pertinent rules concerning the Skill will follow.

FORMATS

Skills are presented in three basic formats. Most Skills are in the first format which is the simplest. All other non-combat Skills are in the second format. The third format is reserved for Combat Skills.

- Format 1:** The values for the score in this format range from 0 to 100.
- Format 2:** The principal values range from 0 to 100 but the Skill has a secondary area of expertise which has a value equal to one half the principal score. This secondary area may be improved independently of the principal area. Once it is raised independently, it essentially becomes a separate Skill of format 1 and the principal area does the same.
- Format 3:** This type of Skill acts as a format 1 Skill, but there is a second range of value beyond the score of 100. This range goes from 101 -200. Score in the second range cannot be accumulated until the score in the first range equals 100.

Lockpicking Skill is a Format 1 Skill. The score ranges from 0 to 100. The BCS is the score divided by 5, rounded down. The Average BCS is the normal BCS divided by 2 rounded down.

Stealth Skill is a Format 2 Skill. The score ranges from 0 to 100. The Skill has Rural and Urban areas of expertise. If a character's principal area of expertise is Rural, his BCS when using Stealth Skill in a rural environment will be the score/5, down. When in a urban environment, the BCS will be the score/10, down. The character may at any time elect to treat the Urban area as a separate Skill and any improvements to the score (which will start at one half the score in the principal area) will be separate. Once the areas are separated into Skills, they will become as Format 1 Skills except that the two Stealth Skills will only count as one Skill with regard to the character's Freely Improvable Skills.

Single Weapon Combat Skill is a Format 3 Skill. The score range is from 1 to 200. The normal BCS for use of the Skill is the score in the first 100 points divided by 5 and rounded down. The average BCS is total score divided by 10, rounded down. The BCS derived from the second 100 points in the Control Throw. The score in the 100 points divided by 20 and rounded down is the number of contiguous Locations by which the target Location may be altered. This function is not allowed when an Average BCS is being used.

Thus, a character with a Lockpicking Skill score of 48 has a BCS of 9. A character with a Stealth Skill score of 48 and a principal area of Rural has a BCS of 9 in a rural environment and a BCS of 4 in an urban environment. A character with a Single Weapon Skill score of 148 has a BCS of 20, an Average BCS of 14, a Control Throw of 9 and a Location alteration of 2.

BASIC CHANCE OF SUCCESS

The Basic Chance of Success (BCS) is determined by dividing the character's score in the Skill to be used by 5 and rounding down. This will yield a number from 0 to 20. The number yielded by the calculation is considered the Base BCS. This will be modified by various factors to give the Adjusted BCS. It is this number that the player must roll less than or equal to on 1D20 in order for the character to be successful in using that Skill.

When dealing with Format 3 Skills only the first 100 points generate the Basic Chance of Success to average with the Averaging Skill BCS for the modified BCS. The Control Throw BCS is also averaged in the same way. To determine the character's ability to "aim," average his normal number of alterations to the Location with the score in the Averaging Skill divided by 20 and round down. As with normal averaging, this will not increase the character's "aim" ability. Averaging is always rounded down.

The use of the Basic Chance of Success in combat is dealt with at length in the section on Detailed Action Time on page 20. From the rules players can see how the concept of BCS works and can extrapolate its use for situations not specifically covered.

A player can be asked to make a BCS roll for his character when the character is attempting to do something within the province of one of his Skills or when he is "searching his memory" for some piece of information relating to the field in which the Skill is used.

EFFECT NUMBERS

In order to gauge the results of an application of some Skills, an Effect Number is used. The Effect Number is the difference between the Basic Chance of Success die roll result and the modified Basic Chance of Success. This number is then used in a way which will be specified with the description of the Skill that uses an Effect Number.

AVERAGING SKILLS

Some Skills are designated as Averaging Skills. This means that a character attempting to utilize another Skill while operating in the province of an Averaging Skill will use a modified Basic Chance of Success. The scores that the character has in the Skill he is attempting to use and in the Averaging Skill are added together. They are then divided by 5 and rounded down to yield the modified BCS. This BCS may not exceed the normal BCS of the Skill that the character is attempting to use, although it may exceed the normal BCS of the Averaging Skill unless the Averaging Skill is a Combat Skill.

When dealing with a Combat Skill as the Skill that the character is attempting to use, any BCS after averaging that exceeds 20 becomes the character's modified Control Throw. This will also affect his "aim." A simple rule is that he will have 1 point of Location modification for each 4 points of modified Control Throw.

Beast Riding Skill is designated as an Averaging Skill. This means that when a character wishes to use another Skill such as Single Weapon Combat while mounted on a horse, he must average his scores in Single Weapon Combat and Beast Riding Skills.

"Hawk" Jensen has a score in Single Weapon Combat of 62 (BCS equals 12) and in Beast Riding of 94 (BCS equals 18). His opponent, Jake the Shiv, has values of 152 (BCS equals 20; Control Throw equals 10; Aim equals 2) and 40 (BCS equals 8), respectively. Hawk would have an effective score to determine his BCS of 156/2 or 76. This yields a BCS of 13. This is greater than his normal BCS with Single Weapon Combat of 12. Therefore his modified BCS is lowered to 12. He is at no disadvantage for being mounted. Jake's average score is 192/2 or 96 yielding a BCS of 19. This leaves Jake still superior to Hawk in Combat Skill but Jake has lost his Control Throw and his Aim.

If Jake's Beast Riding Skill had been 66, his averaged score would have been 218/2 or 109. This would have given him a BCS of 20, a Control Throw of 1, but still no aim. If he had been a superb horseman with a score of 100, his averaged score would have been 252/2 or 126 yielding a BCS of 20, a Control Throw of 5 and an Aim of 1.

RAW TALENT VERSUS TRAINED SKILL

As noted in the section on Talents, if a character does not have a score in a Skill that he wishes to perform, he may use his score in the Governing Talent for that Skill as if it were his score in the Skill. To that Basic Chance of Success that is derived from that number, he may add any inherent BCS modifications that arise due the tools required to perform the Skill. The most common kind of inherent modification comes from the use of a gun.

Once the character's score in the Skill is such that the Basic Chance of Success exceeds the Basic Chance of Success that he would have by using the BCS generated by the Governing Talent and any inherent BCS modifications, he must use the BCS generated from his score in the Skill. He will no longer receive any inherent BCS modifications. They are only compensations for a person untrained in the proper use of such things.

Jo the Strong does not have Rifle Combat Skill but his Combative Talent is 20. He finds himself in a firefight with a carbine in his hands. The carbine has an inherent BCS modification of plus 3. His Basic Chance of Success derived from his Talent score is 4. Thus Jo's base BCS with the carbine is 7. This will be modified by Restrictions, Distractions, and other Situational Modifiers as would any normal Basic Chance of Success.

When Jo finally gets to learn Rifle Combat Skill and his score exceeds 35 which gives a BCS of 7, he will be using the Basic Chance of Success generated from the Skill score. He will no longer receive the benefit of inherent modification for the carbine. Until then however, his BCS will be 7 due to Talent and the weapon. This can be thought of as sort of a minimum

VARIATION IN CHARACTER STANCE DUE TO POSITIONING

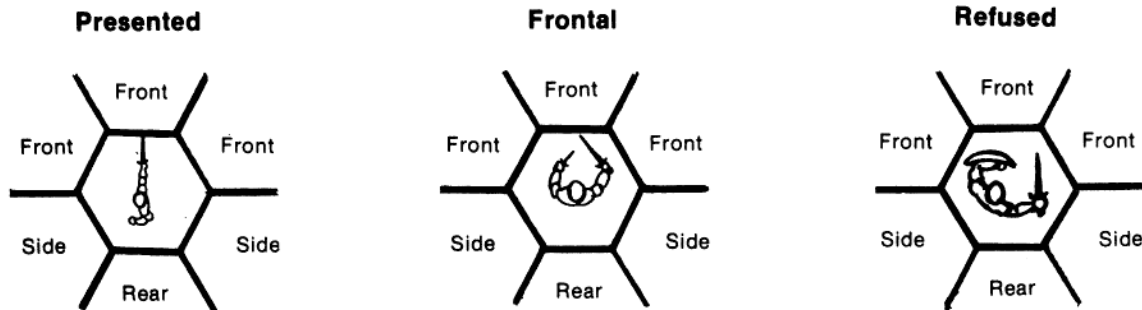

Percentage Breakdown of exact hit Location for attack coming from surrounding hexes

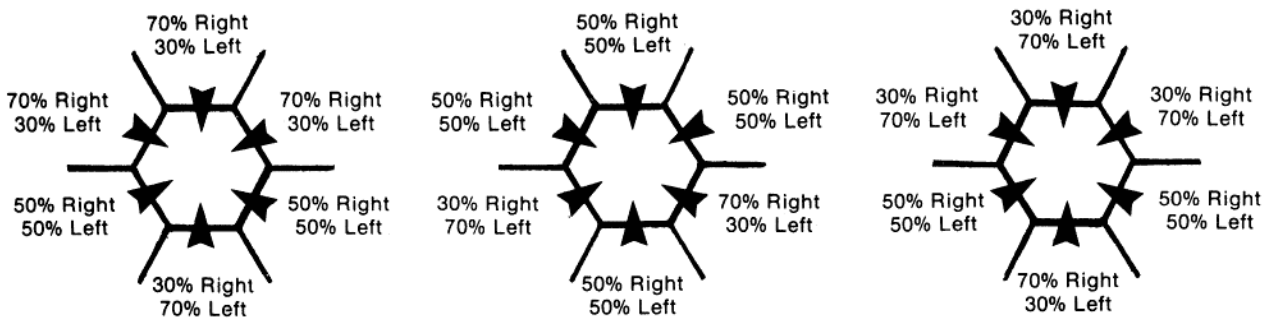

base BCS built from the character's raw ability and the ease of use and quality of the tool in use.

PREREQUISITES TO SKILLS

Some Skills are designated as requiring a Prerequisite Skill. This means that a character must have a score of at least 25 in the Skill or Skills specified as being prerequisite to the Skill he wishes to learn before he can acquire a score in that Skill.

COMBAT SKILLS

There are several things peculiar to Combat Skills and so they are dealt with in this section. Combat Skill will, when in use, result in the character having a certain positioning. This is used as a modification to the exact Location of a hit in combat. It is particularly pertinent in determining which arm or leg is hit. Also, Combat Skills have chances for Aim and Control Throws arising from the second range of score.

POSITIONING DUE TO SKILL IN USE

Each Combat Skill will be specified as frontal, presented or refused. Frontal positioning indicates a 50-50 chance of either side of the character being hit when struck through a Front or Rear hex. A 70% chance of hitting the side that the attack is coming from occurs when the strike is made from a Side hex.

Presented and refused each have a 70% chance of striking the weaponed or non-weaponed side respectively when the attack is made through a Front hex. An attack from a Side Hex has a 50% chance of striking either side of the character when successful. An attack from a Rear hex reverses the probability of the Front hex attack. That is an attack against a character in Presented positioning has a 70% chance of striking the non-weaponed side and against the character in Refused positioning it has a 70% chance of striking the weaponed side.

A character with Presented positioning is attempting to keep his body in profile to his opponent with his primary weapon between him and his opponent. A character will hold his primary weapon in his favored hand unless otherwise specified. This side is considered the weaponed side. The other side is referred to as the non-weaponed side.

A character with Refused positioning is also attempting to keep his body in profile to his opponent but he holds the weapon in his favored hand away from his opponent with his body between it and his opponent. A character using this positioning usually has something else to interpose between his body and his opponent such as a shield.

PRIMARY AND SECONDARY ATTACKS

Some weapons are noted as being capable of secondary attacks. The use of such an option is left to the player controlling the character. It is not required. If it is to be used, the attempt to make a secondary attack must be specified to the Gamesmaster when the character is initiating his Attack Action. During the phases that pass while the character is conducting the Attack Action, he is considered to be without benefit of his normal Weapon Defense Ability. The secondary attack will have an effective score, to convert to Basic Chance of Success, of one half the total score in that Combat Skill. For example a character with a score of 150 would derive the BCS and Aim for a primary attack from a score of 150 and a secondary attack from a score of 75.

WEAPONS DEFENSE ABILITY IN COMBAT

A character using a Hand-to-hand Combat Skill has a Weapon Defense Ability (WDA) against opponents using Hand-to-hand Combat Skills to attack him. The value for this Ability is subtracted from the opponent's Basic Chance of Success. When a character using a Missile Combat Skill is engaged by an opponent using a Hand-to-hand Combat Skill, he may use a skilled or unskilled unarmed-combat Combat Skill to generate a Weapon Defense Ability. When doing this the character will suffer a negative modification to his own Basic Chance of Success when he resolves his missile attack. This modification will be equal to the Weapon Defense Ability used by the character with the missile weapon.

The Weapon Defense Ability is calculated from the first one hundred points of score in the Combat Skill. It can easily be different for each Hand-to-hand Combat Skill that the character has score in, it is equal to the score in the Skill (first 100 points only) divided by 20 and rounded to the nearest.

AIM WITH A COMBAT SKILL

When a character had gained enough skill in a Combat Skill he will begin to be able to "aim." For each point of Aim, the Location of a hit on the body map may be altered by one Location. These must be contiguous Locations and follow the transference lines on the accompanying diagram. The use of Aim points is not required and, if used, all need not be expended. Aim points are not cumulative from attack to attack.

Aim is calculated similarly to Weapon Defense Ability except that the second 100 points of the score in the Combat Skill are used. That is,

Aim Points equal $(\text{Score} - 100) / 20$, down.

ALTERATIONS DUE TO AIM

The Dot Pattern connects contiguous Locations on the Body Map.

Deliberate Miss

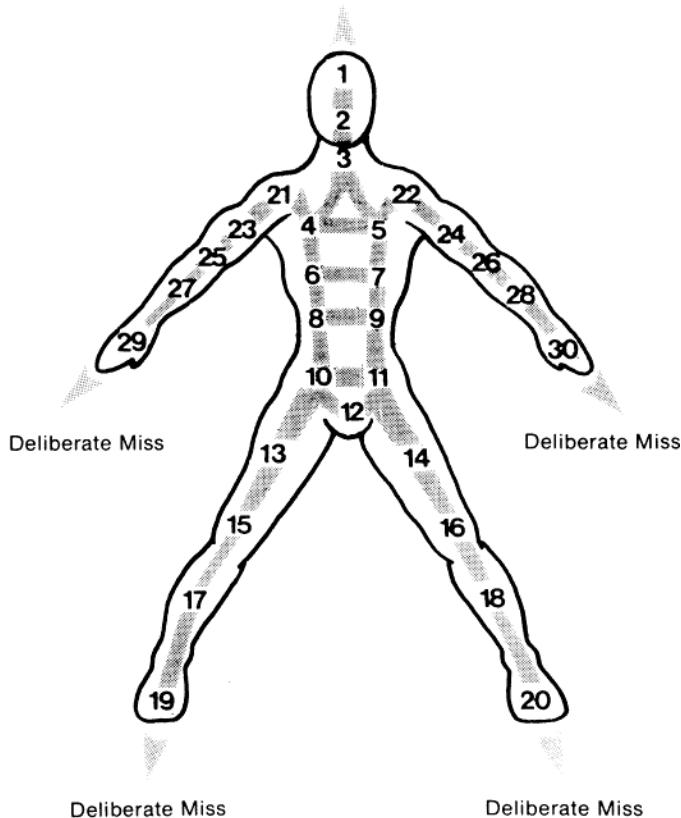

For items which are presented in the weapons, armor or equipment lists, we will give a specific ENC value. These values can be used by a Gamesmaster as a guideline in tailoring specific Encumbrance values for items which are introduced to the campaign.

DISTRIBUTION OF ENCUMBRANCE

A character has a limited amount of space over which he may distribute a load upon his person. This is broken down into areas such as his hands, his back, at his belt and slung from his side. The character may wear or carry containers at these locations which will hold other items. Each container will be rated according to the maximum ENC value it will hold and the maximum bulk grouping which will fit into the container's opening. Once an item is placed into a container its effective ENC will be halved. This half value is what is assessed against the character's Encumbrance Capacity. However, the item's full ENC value is what is assessed against the container's maximum capacity. Containers such as backpacks, when worn properly merely occupy space and do not count against the total Encumbrance value that the character is carrying.

A character may carry:

- 1 "thing" on his back.
- 1 "thing" up to Very Large in each hand.
- 1 "thing" slung over each shoulder.
- 10 "things" on a belt.

It should be noted that a "thing" may actually occupy more than one position on a belt. For example, a tool kit designed for belt wear is only one "thing" for determining its ENC value but it will take up about 5 places on a belt.

Armor and clothing that is worn should have the total ENC value of each garment or item calculated and the total of the ENC value for all the garments and items is the ENC value that will be assessed against the character's Encumbrance Capacity. Any garments or items of armor that are carried rather than worn will have their ENC values doubled.

ENCUMBRANCE VALUE CHART

BULK	MASS			VHvy	MS1	MS2	MS3
	Vlt	Lt	Hvy				
VSm	0.001	0.05	0.1	0.6	1.0	2.0	3.0
SM	0.05	0.1	0.6	1.0	1.6	3.5	5.0
Med	0.1	0.3	1.0	1.6	2.0	5.0	7.5
Lg	0.3	0.6	1.5	2.0	3.5	7.0	10.0
VLg	0.6	1.0	3.5	4.5	5.0	10.0	15.0
HG1	2	3.5	5.0	6.0	8.0	16.0	22.0
HG2	4	7.0	10.0	12.0	16.0	32.0	44.0
HG3	6	10.5	15.0	18.0	24.0	48.0	66.0

BULK

VSm	very small	able to be hidden in a hand, such as a coin, gem, small jewelry, etc.
Sm	small	can be held and used with one hand and does not project far from the hand, such as knives, candles, clubs, lanterns, etc.
Med	medium	held and used in one hand but significantly larger than the hand, such as short swords, torches, etc.
Lg	large	usable in one hand and up to about a meter in length, such as swords, large tools, bundles, etc.
VLg	very large	able to be held or carried in one hand but usually requiring two hands to use properly, such as staves, longbows, polearms, crossbows, rifles, etc.
HG	huge	greater than 6 feet long and bulky, usually requires two hands to carry
HG1:		mattress, small giant, coffin, etc.
HG2:		horses, carts, small car, etc. and so on.

CONTROL THROWS DURING COMBAT

When a character in combat rolls a 20, he is subject to a Critical Miss. However, the player may attempt to make a Control Throw for his character to avoid the effects of the Critical Miss. If the throw is made, there will be no Critical Effects to the miss. If not, the Gamesmaster will roll on the Critical Miss Effects Table to see what has happened to the hapless character.

Control Throw equals

$(\text{Score}-100)/5$, down and is treated as if it were a normal BCS.

When used with Missile Combat Skills this Control Throw indicates that the character has been careful before hand and has not used inferior or defective equipment or ammunition. In such cases treat as a normal miss. With such things as bullets, have the player remove an additional round from the character's total of ammunition since the Control Throw indicates that the round in question was discarded as defective.

THE THRUST IN COMBAT

Any weapon classified as capable of a thrust may be used to deliver one. The player must specify that the character is using a thrust before the attack is resolved. A thrust will add 1 to the Basic Chance of Success but will lower the effective Strength Group by 1 for purposes of determining the Effect Die. A thrust has a percentage chance of achieving a special effect equal to the Damage Potential. If this occurs it is treated as a Missile Special Effect.

ENCUMBRANCE

The encumbrance system is a way of measuring how much of a load the character is carrying and how the distribution of that load will affect the character when he attempts to perform various actions while carrying the load. Each character has an Encumbrance Capacity which is the maximum value of Encumbrance (ENC) that the character may carry on any kind of a sustained basis. The Encumbrance value of any item is rated on an abstract scale which compares the bulkiness of an object to its mass. A simplistic expression of this is presented in the Encumbrance Value Chart below. This chart will yield a rough figure for the object being considered which may then be adjusted by the Gamesmaster as he feels proper to reflect the Encumbrance value of the item. In general, an item designed to be handled or stored conveniently will have a lower ENC value than an item of the same mass and bulk which has many protrusions or is of an awkward shape. Representative examples of each bulk and mass classification are given following the chart.

MASS

VLt	very light	wood, paper, feathers, cloth, etc.
Lt	light	flesh, leather, water, heavy woods, etc.
Hvy	heavy	stone, gemstones, iron, brass, etc.
VHvy	very heavy	lead, silver, etc.
MS	massive	MS1: gold, platinum, etc. MS2: uranium, plutonium, etc.

and so on

ENCUMBRANCE STATUS

Once a player has calculated his character's Encumbrance Capacity and the Encumbrance Total of all gear carried and worn, the character's encumbrance status may be determined. The requirements for each status and its effects are listed in the table below.

Status	Deftness	Speed	BCS
Unencumbered up to 1/2 ENC CAP		no modifications	
Partially Encumbered up to 3/4 ENC CAP	-25%	-25%	-1
Fully Encumbered up to full ENC CAP	-50%	-50%	-2

As with other percentage modifications to Attribute scores the percentage is taken from the effective score. The BCS modification applies only to Skills which require physical exertion or the exercise of dexterity. They do not apply to any Skills which are cerebral in nature.

Yusof Strongarm is getting ready to go adventuring and is packing up his gear. Into a pack (ENC CAP 10) go: a bag with field rations(10 at 0.1 each), a bag with 10 bandages (0.05 each) and 5 units of medical supplies (.1 each), a bag with a hammer (.6) and 5 iron spikes (.4 each), and a full 5 liter water skin (1). This has a total Encumbrance value of 5.6. He shrugs the pack into place on his back. Once there it will add 2.8 to his Encumbrance Total.

The value for the clothes and armor that he is wearing is 0.17. This brings his Encumbrance Total to 2.97.

Yusof belts on his sword(.7) and stuffs a pistol (.3) into his belt. He slings a coil of rope (1) over his right shoulder and a shoulder bag over the left. The bag contains 10 spare rounds for the pistol (.01 each) and a repair kit for the gun (.5). In the bag, they have an effective Encumbrance of 3. This new gear raises his Total by 2.3 to 5.27.

He then takes up a quarterstaff in his right hand for an additional Encumbrance of 1. The final Encumbrance Total is 6.27.

Yusof has a Strength Group of 4 and a Deftness Group of 2. This gives him an Encumbrance Capacity of $(3 \times 4) + 2$ or 14., Thus, load he is carrying will put him at Partially Encumbered status. If he rids himself of the staff before going into action, he will be in Unencumbered status.

ACCESS TO STORED ITEMS

In order to get an item which has been stored in a container, the character must get access to the container, open it and sort the desired item out from the other items in the container. The time taken in doing this can be of serious importance if this is being done in the middle of a desperate situation. The player should state that the character is beginning to get an item and inform the Gamesmaster of where it is kept. The character will then be engaged in the process for a number of Actions. The exact number should be known only to the Gamesmaster, The will announce to the player that he has found the item sought at the end of the Action on which it is "found."

To determine which item the desired one will be when items in a container are gone through, the Gamesmaster will roll a die with a range equal to the number of "things" in the container. If the number of "things" is not equal to one of the standard ranges, the Gamesmaster should roll the die with the next largest range and reroll if the result is outside the range determined by the number of "things." The result of the die roll will indicate which item the desired one will be. A character may sort through a number of "things" equal to his Deftness group in each Action.

The method of closure used on the container may also affect the time involved. A container that is unsealed or closed only by a snap or Velcro-type seal will not add to the time involved. A button or buckle will add 1 Action for each button or buckle involved. If the container is closed by being tied, it will add 3 Actions.

OPTION

A character may cut the overall time down by making a Deftness Saving Throw. The results of the throw are kept secret by the Gamesmaster since it will affect when the character finds the sought after item. If the die roll result is in the character's Ability Saving Throw range, the time will be cut by 1/3,

rounded to the nearest Action. If the result is in the character's Critical Saving Throw range the time will be cut in half, rounded to the nearest.

Yusof of the previous example is in Detailed Action Time and finds that he needs some of his medical supplies. With his Deftness Group of 2, he will have two Actions per Combat Turn. He will spend the first turn taking off his pack, since it requires two Actions to do so. The backpack is held closed by two buckles so it will take Yusof another turn to open the pack. Because all the items in the pack are in separate bags, the Gamesmaster rules that there are 4 "things" in the pack. The Gamesmaster rolls 1D4 (Roll 1D6 and ignore results over 4) and the result is 3. Since Yusof's Deftness Group is 3, he will get the right bag on the first action of sorting. Because there are two bandages to each unit of supplies, there is a 1 in 3 chance that each "thing" gone through in the small bag will be a unit of supplies. Yusof can check up to 3 "things" per Action. The Gamesmaster starts rolling 1D3 for each item sorted. The second die roll is a 1 so the "thing" is a unit of supplies. The total number of Actions would be six. Yusof is in a hurry so the player elects to attempt a Saving Throw to cut the time. The Gamesmaster rolls 1D20. The die result falls in Yusof's Ability Saving Throw range. This means that the time in terms of numbers of Actions will be cut in half, to three. The Gamesmaster will announce that Yusof has a unit of supplies in his hands at the end of the third Action from the time that the player announced that Yusof was beginning the attempt. If interrupted, Yusof would have to pick up the process again from where he left off. A new calculation of the time required should be made.

PERSONAL MASS

A character's mass must be known to determine the Encumbrance Total for any mount the character may ride and for calculations involving Bash effects. Personal Mass is equal to the character's Personal Encumbrance plus one-third his Encumbrance Total, rounded down.

A character who is charging will increase his Personal Mass by 50%. An unconscious character will have his Personal Encumbrance increased by 50% before the Personal Mass calculation. A struggling character trying to avoid being carried off will have twice his normal Personal Encumbrance for purposes of making the Personal Mass calculation.

BIPEDAL HIT LOCATION MAP

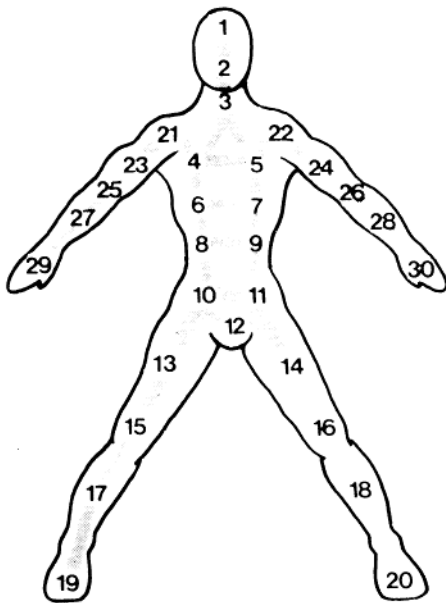

LOCATION AND ARMOR

This system has the human body divided into 30 areas. Each is referred to as a Location (LOC). When a character is successfully attacked, 1D100 will be rolled to see where the attack landed on the Location map. Generally, a level on the body will be indicated. A die roll of 20 indicates LOC 4/5. If the character struck is presenting either his front or back to the direction of the attack there is a 500/a chance that LOC 4 will be struck, and, if Loc 4 is not indicated, then Loc 5 is struck. When the character is facing in such a direction that one side of his body is closer to the direction of the attack, there is a 70% chance that the side facing the direction of the attack will be the one that is struck. In the case above, if the attack had been coming from the character's left side, there would have been a 70% chance that LOC 5

would receive the attack. If the die roll was greater than 10 on 1D100 than LOC 4 would have been the target.

A quadrupedal body is also represented by 30 Locations but in a different fashion. When a level on the body is indicated the third LOC listed represents the underbelly of the animal. The percentage determinations for the exact Location works in much the same way as for bipedal forms. The specifics along with the Hit Location Tables are presented on page 28.

Once the exact Location of the strike from a successful attack is known, the protection on that Location must be checked. This protection may be from hide, clothing or armor. It will be rated for an Armor Value or AV, This Armor Value will be subtracted from the Damage Potential derived from the attack to determine the actual damage done to the character receiving the attack.

Armor and clothing materials are rated for their Armor Value as well as their ENC for each point that they cover. From these values the protection of the garment and its total ENC value can be calculated. This has already been done for items in the lists of standard gear. It is important that armor and clothing be treated as garments and not just isolated pieces.

Only the best Armor Value that a character has covering a given Location is used to subtract from the Damage Potential. However the total ENC value for all items worn is assessed against the character's Encumbrance Total.

QUADRUPEDAL HIT LOCATION MAP

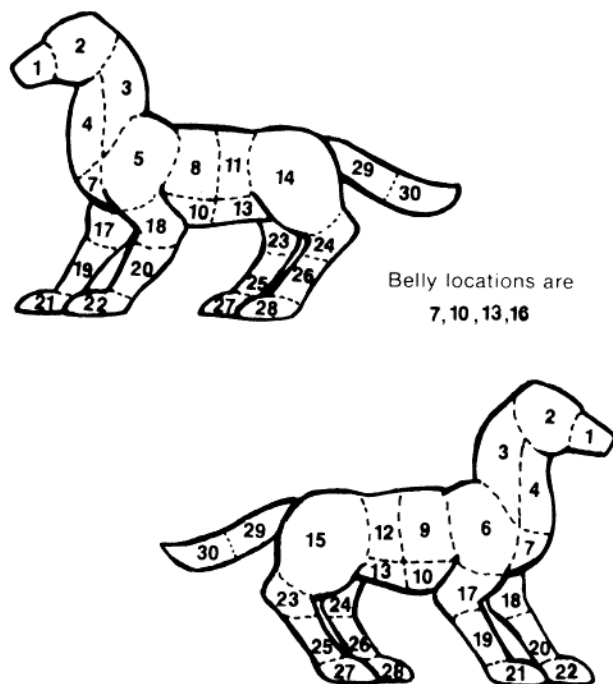

OPTION ENHANCED ARMOR VALUES

Under this Option a character receives the Armor Value of additional layers worn on top of or underneath his best armor. He does not, however, receive the full value. Each extra layer will have an Armor Value equal to its normal value divided by 4, rounded down. The character is still subject to the full encumbrance values of the extra layers.

This Option is a more accurate reflection of reality but tends to make the game less "sporting." It is only recommended for detail fanatics who wish even more calculations.

ARMOR FORMATS

Each of the various types of armor that a character can wear is specified as having a format. These formats are Rigid (R); Semi-Rigid (SR); Flexible, Hard (FH); Flexible, Soft (FS) and Flexible, Quilted (FQ). The format of an armor is important for determining its use when an armor is reinforced and when the character is subject to damage due to constriction.

REINFORCING ARMOR

All Flexible, Quilted materials may be "quilted" to yield a more protective armor. This increases the Armor Value by 1 and doubles the ENC value for each Location the garment covers. This process may be done properly by

any character with Tailor Skill. To indicate that the armor has been treated in this fashion the designation 'Q-' is placed in front of the code for that type of armor. Thus Heavy Cloth with a designation of HO, a format of Flexible, Quilted and an ENC value of .0008 per Location would, when quilted have a designation of Q-HC, the same format and an ENC value of .0016 per Location covered. It would also have its Armor Value increased from 2 to 3.

All Flexible, Soft and Flexible, Quilted materials may be Reinforced. The Reinforcing will raise the Armor Value by one third the Armor Value of the Rigid format reinforcing material rounded to the nearest. The ENC value per Location will be raised by the ENC value of the Rigid format material. The format of the resultant armor will be Flexible, Hard. A given armor may only be Reinforced once, although a Flexible, Quilted material may be both Quilted and Reinforced, If the example above were to be Reinforced with bronze studs (Designation: BP; Format: R; ENC: .06), its new designation would be R(BP)-Q-HC. Its new Armor Value would be 3 + (6/3) or 3 + 2 or 5 and its ENC value per Location would be .0016 + .06 or .0616. Any character with Armorer Skill may Reinforce armor.

Only those armor materials dealt with above may be reinforced in any way.

LEATHER AND HIDES AS ARMOR

Any character with Leatherworker Skill can properly cure a hide to yield the standard Armor Value for the type of hide being worked. These values are specified in the Armor Materials Listing in Book 2. A character who fails his Basic Chance of Success roll or one who does not have Leatherworker Skill will get a badly cured version of the hide that will have an Armor Value of 1 less than normal. It cannot be later hardened.

Any leather that is of Flexible, Soft format may be Hardened by a character with Leatherworker Skill to increase the Armor Value by 1. This will add 'H-' to the materials designation and change its format to Flexible, Hard. It will not alter its ENC value per Location. A material may not be Reinforced after it is Hardened nor may it be Hardened after it is Reinforced.

IMPROVISING ARMOR MATERIALS

Any character may improvise armor. A character with Armorer Skill who does not have the proper facilities will only be Improvising. Improvised armor will only have one half of its normal Armor Value. This rule is designed to deal with things that were not originally meant to be used as armor being pressed into service by a character who is without useful armor.

USE OF ARMOR TO PREVENT DAMAGE

Against most forms of attack, the Armor Value of the material covering the Location which is hit will be subtracted from the Damage Potential. In the case of constriction attack, the format of the material will affect its Armor Value. A Rigid format material will have an effective Armor Value of twice its normal value until this doubled value is exceeded by the Damage Potential on one phase. At this point, the armor Value will be effectively 0 since the material is considered crushed beyond use. A character will receive an additional amount of points of Subdual damage equal to the normal Armor Value of the Material when the material is removed. This must be done before any healing can be done to the injured area.

Semi-Rigid, Flexible Hard, and all Reinforced materials will have their normal Armor Value against the first constriction. On successive turns their value will be reduced by half, rounded down, until the source of the constriction is removed. A second constriction on the same Location allows the process to begin again.

All other formats of armor materials provide no protection against constriction at all. They have an effective Armor Value of 0.

AVERAGE ARMOR VALUE

The Average Armor Value is used to defend against attacks upon the character made by multiple small objects such as occur with fragmentation type effects. It is also the basic rating of the character in the Tactical Combat System.

Average Armor Value is calculated by summing the best Armor Value on each Location, dividing the result by 30 and rounding to the nearest.

Yusof of the two previous examples is wearing armor and clothing of the following characteristics:

Item	Location Coverage	Code	Armor Value	Total ENC
Steel helmet	1	SP	9	.07
Clothing	4-18 & 21-28	HC	2	.01
Heavy Leather Torso Armor	4-12	HL	4	.07
Light Leather Calf Boots	17-20	LL	3	.02

This yields a total Encumbrance value of .17

To determine the Average Armor Value only the best armor on each Location is considered. On Location 1, there is 9. On Locations 2 and 3, there is 0. On Locations 4 to 12, there is 4. On Locations 13 to 16, there is 2. On Locations 17 to 20, there is 3. On Locations 21 to 28, there is 2. On Locations 29 and 30, there is 0.

This gives one Location with 9, nine Locations with 4, four Locations with 3, twelve Locations with 2 and four Locations with 0. The total of the Armor Values is 9 + (9 x 4) + (4 x 3) + (12 x 2) + (4 x 0) or 936 + 12 + 24 + 0 or 81. This is divided by 30 to give 2.7. This is rounded to the nearest to give an Average Armor Value of 3.

OPTION DESTRUCTION OF ARMOR

If the Damage Potential or BDG of an attack exceeds the armor Value by three times its value the armor on that Location is considered destroyed starting on the next phase. After combat a character with an appropriate Skill forworking the material may restore it to one half Armor Value until repairs can be made to restore it to full value.

TIME AND MOVEMENT

Once the characters' adventuring careers have begun, time in the game will pass at different rates. The time scale in use in any particular instance depends on several things. How the characters are traveling, what they are trying to do and what is happening around them all have bearing on the time scale to be used. The Gamesmaster will make the decision as to which scale is to be used. He will then ask for appropriate responses from the players with regard to their characters' actions and intents. The scales for the passage of time in the game which are defined here are: Strategic, Tactical, Detailed Action Time, Real Time and Down Time.

STRATEGIC TIME SCALE

Strategic time scale is usually used when the characters are doing long distance traveling. A day is divided into two Strategic Turns, one for the day and one for the night. The characters are assumed to travel during one of the turns and rest during the other. If the players wish to have their characters travel for more than one consecutive Strategic Turn, they will be subject to the Forced March rules on page 19.

During each Strategic Turn the Gamesmaster will make a check to see if the characters have an Encounter. The procedure for this is presented in Book 3, If the characters do indeed have an Encounter, the Gamesmaster will probably switch to one of the other time scales in order to resolve the interaction between the characters and whatever or whoever they have encountered.

As the characters travel, the Gamesmaster should describe to the players the nature of the terrain through which the characters are traveling. This would include the nature of the vegetation, any significant geographical features and any man-made structures. If a location or a feature is well hidden or off the direct route that the characters are following, the Gamesmaster may wish to roll 1D20 to see if the travelers will discover the "Hidden Thing."

Locations that are preplanned by the Games master may well have guards, outposts or some kind of outlying group that might interact with a traveling group of adventurers when they draw near. The Gamesmaster should make a special encounter check for this. Such things may lead the characters onto an unplanned adventure, unplanned by them that is.

TACTICAL TIME SCALE

Tactical time scale is most flexible with regard to the length of a Tactical Turn. The exact length of a Tactical Turn is left to the Gamesmaster's discretion and can vary from one turn to the next. It is intended that the Tactical scale cover time periods ranging from 10 minutes to 1 hour.

Tactical scale should have the length of its turn reflect the complication of the action to be resolved. The more complicated it is, the shorter the period should be. Thus, when characters are traveling through something like a ruined city in which the Gamesmaster has located several prepared areas but has not mapped the whole city in close detail, a turn of an hour's length would be appropriate. When the characters reach one of the pre-designed areas, the time scale should be altered to turns lasting 10 or 20 minutes.

A variation on Tactical time scale is used with the Tactical Combat rules and is presented with those rules in Book 3.

DETAILED ACTION TIME SCALE

Detailed Action time scale is used when determining the results of such intricate interactions as combat, death traps, confrontations, etc. Since the most common use of Detailed Action Time (DAT) is combat, a turn is

referred to as a Combat Turn. The actual time represented by a Combat Turn is about 6 seconds. Each Combat Turn is divided up into Action Phases. This is done to break down the complex interpenetration of complicated actions occurring almost simultaneously into sort of a "slow motion" where each action can be considered and resolved in the light of the other actions taking place around it. The specifics of Detailed Action Time are involved and are treated in their own section on page 20.

REAL TIME SCALE

Real Time scale is a variation of Detailed Action Time in that it is a short time scale and is used to handle short, complicated interactions such as conversations or unusual actions not accounted for in the standard rules. When Real Time is invoked, it is the players rather than the characters who are consuming the time in the game. That is to say, that however long it takes players to complete their conversation or whatever, is how long it will take the characters to finish the same conversation. Naturally, things will continue to happen around the characters. If something that would impinge upon the senses of the characters happens, the Gamesmaster should inform the players of this at the point it happens as if the characters noticed it while they were performing their actions.

The Real Time scale is where much of the role-playing in a Role Playing Game comes from. Here players frequently act as their characters in a literal sense. Some players even develop accents or characteristic methods of speech so the other players will know when it is the character speaking instead of the player.

DOWN TIME SCALE

Unlike the other time scales, Down Time is not used during an adventure, it is used between adventures. The game time consumed can vary from days to weeks to months to years. This is the time scale to be used when the characters are Studying, Researching, Rebuilding, etc.

The Gamesmaster, unless specifically requested by the players, should always allow the characters to have some Down Time between adventures. During Down Time, the usual hazards of the town, ruins, or wilderness are considerably reduced or, if the Gamesmaster is in a good mood, nonexistent. When a regular campaign is being run, a good scale to use is a week of actual time between gaming sessions corresponds to a month of game time. This allows a greater flow of time in the game and players can thus see their successful characters live out a lifetime in something less than the players' own lifetimes.

As noted above the flow of time in Down Time Scale is flexible and the Gamesmaster may wish to vary the Down Time between adventures to be more suitable to the campaign or the particular series of adventurers that the characters have embarked upon. When the time in this scale extends much beyond a month and the players wish to have their characters engaged in constant Study or Research, the Gamesmaster should take human nature into account. Characters will get bored or exasperated with what they are doing and will not apply themselves fully. In this fashion, not all the time will be available for the characters to increase their Skills or build things. Sometimes, even a character will need a vacation from the constant hard schedule that a player will outline for him. The Gamesmaster might require the character to make a Will Saving Throw, at various intervals, in order for the character to remain dedicated to the player's regimen of studies or other procedures.

During some adventures the gaming session will end before the particular scenario is completed. In such cases, it is best to "freeze" the action in place. The positions of all characters should be carefully noted along with what they were doing when the action was "frozen." At the next game session the action may be resumed where it left off at the last session. When this occurs frequently, the Gamesmaster may wish to allow a longer than usual period when next he allows Down Time.

COMBINING TIME SCALES

There will come times in the course of a campaign when the Gamesmaster will find that a combination of more than one time scale will prove a superior way to handle a situation. A fight that uses missile weapons at ranges over 50 meters is a good example. Characters can still resolve their actions as if they were in Detailed Action Time for purposes of what they can do and when they can do it. For movement if characters are trying to close the distance between the hostile groups, the use of Tactical Scale movement is recommended. The Gamesmaster may keep track of such actions by noting the positions of all involved parties on his Tactical Scale map and only shift to the Detailed Action Time Display when the opponents are about 20 meters apart.

Often when doing this, the Gamesmaster may wish to represent each party as if they were on the DAT Display and use a Tactical Display where

each hex is 10 meters (or some other appropriate number). A marker on the Tactical Display would be used to indicate each of the Tactical Display hexes that has one or more characters in it. This technique aids the players' grasp of the tactical situation. It is recommended when feasible.

MOVEMENT IN TACTICAL OR STRATEGIC TRAVEL

Each character will have a movement rate for a day's travel. This rate assumes ten hours of travel and includes proper rest breaks. A character wishing to exceed these rates is subject to the Forced March rules. The basic rates are subject to modifiers due to terrain and weather conditions.

A character's basic traveling rate is equal to 10 plus his effective Speed in kilometers. This is for one day's travel. For the hourly rate, simply divide by 10.

When calculating the modified travel rate, all the percentages in the chart below should be treated as decimals and multiplied consecutively by the basic travel rate.

J.J. Jones is traveling through hills (x .5) on a Good Road (x 1.0) on the second day after a Light Snow (x .75). With a Speed of 32, her daily travel rate is 42 kilometers and her hourly rate is 4.2 kilometers. A day's travel under the conditions above, therefore, will be $42 \times .5 \times 1.0 \times .75$ or 15.75, rounded to 16 kilometers that day. This also means her hourly rate will be 1.6 kilometers an hour.

MOVEMENT MODIFIERS CHART

On Good Road	200%
On Poor Road	100%
On Ruined Road	50%
In Ruined City	25%
In Built-up Area	50%
In Open Terrain	100%
In Rough or Impeding Terrain	75%
In Woods, Hills or Desert	50%
In Forest, Swamp, Jungle, or Mountains	25%
At Night without light	25%
At Night with Dim light	50%
At Night with Good light	75%
In Light Rain or Fog	75%
In Heavy Rain or Fog or Light Snow	50%
In Dense Fog or Heavy Snow	25%
On Day After	
Heavy Rain (day 1)	75% (day 2) 100%
Light Snow (day 1)	50% (day 2) 75%
Heavy Snow	(day 1) 25% (day 3) 75%
	(day 2) 50% (day 4) 100%
Prolonged Snow:	For each additional day of snow add 1 Day at the worst penalty

For calculation purposes remember that 75% is equal to .75, 100% is equal to 1.0. etc.

FORCED MARCH

Forced March entails the character pushing himself beyond the pace assumed in the travel rules. This can be done in one of two ways: the Fast March or the Long March. If either form is attempted on a second consecutive day, a Health Ability Saving Throw is required for it to be used. On the third day, a Health Critical Saving Throw is required. On following days, a Health Critical Saving Throw at one half the normal value is required. If the Saving Throw is not made, no Forced March is allowed on that day. Normal travel is allowed. After one day at normal pace, the ability to Force march is regained.

THE FAST MARCH

This form allows the character to move at double the base hourly rate. The doubled base rate is still subject to terrain modifiers. The maximum number of hours during which the character may move at this rate is equal to the character's Healing Rate. Each hour, or fraction thereof, that the character is moving at this rate beyond the safe limit will do 2D10 of Subdual Damage to the character. This damage is treated like normal subdual damage and may be recovered from in the usual fashion. (See Damage and Healing on page 36.) This damage may lower the base movement rate.

Once the character has passed out from the strain of the Fast March, he may not use Forced March for the rest of the day.

THE LONG MARCH

This form allows the character to continue moving at his normal base rate for more than the normal 10 hours. The maximum number of safe hours that he may do this is equal to his Healing Rate. Each hour, or fraction thereof, beyond the safe limit does 2D10 of subdual damage as in Fast March.

DETAILED ACTION TIME

The scale of play known as Detailed Action Time (DAT) is used for situations where the specific actions of the characters and the time that it takes to resolve such actions are followed in close detail. The most common use of this scale is combat. Therefore one turn in this scale is known as a Combat Turn. One Combat Turn approximates 6 seconds of real time. Each Combat Turn is broken down into a variable number of Action Phases. Each action taken during a Combat Turn will occur on a particular Action Phase. During the Combat Turn the Gamesmaster will count down from the highest numbered Action Phase in which one of the involved characters may act. When the countdown reaches the phase in which a character may act, the controlling player must inform the Gamesmaster of the character's actions. Action Phase 0 is the bookkeeping phase and NO characters may act in this phase.

Various Abilities are involved in the character's execution of actions under the rules of Detailed Action Time. These Abilities are recounted here along with their specific applications.

- Base Action Phase (BAP) equals Speed/2, down. This is the highest-numbered phase in the Combat Turn in which the character may initiate actions in accordance to the Movement and Action rules. The character with the highest BAP in a given Detailed Action Time determines the starting point of the countdown. That point is equal to the character's BAP.
- Phases Consumed in Action (PCA) equals BAP/MNA, down. This is the number of phases that it takes the character to perform an Action during Detailed Action Time. If the numbers of phases left in a Combat Turn is less than the character's PCA, then the character may not initiate an Action during that Combat Turn. The character may, however, move in accordance with the Movement rules for the rest of that Combat Turn.
- Maximum Number of Actions (MNA) equals Deftness Group. This is the greatest number of Actions that the character may initiate and complete in a Combat Turn. A character with an MNA of 0 takes two Combat Turns to complete an action. He has a PCA of $2 \times \text{BAP}$.
- Base Movement Allowance (BMA). This is an ability which is inherent in the species of the character. The BMA of a human is 1. If MNA is equal to 0, then BMA is equal to .5. If a species has a BMA which is different from human BMA, it will be given in the listing of the statistics of that species. The Base Movement Allowance is the distance the character may cover in one phase of normal movement. This movement is measured in meters.

If a character is crawling (moving while in a prone or kneeling position) he will have an effective Base Movement Allowance of one-half his normal value. The "run" increase to BMA is not allowed.

When a character on a Detailed Action Time Display (see below) is moving at less than 1 meter per phase, the marker should not be moved from one 1 meter hex to another until the character has accumulated sufficient movement to account for the 1 meter change on the Display. It is the responsibility of the controlling player to keep track of all partial movements of this nature.

EFFECTS OF PRE-EMPTION & SURPRISE

If a character initiates an Action and thereby causes the Gamesmaster to declare that Detailed Action Time is necessary, the Gamesmaster may decide that the character has "pre-empted" the other characters involved. This means that the countdown of the Action Phases for the first Combat Turn of the Detailed Action Time will begin on the Base Action Phase of the character who initiated the Action which caused Detailed Action Time to begin. Any characters who have higher Base Action Phases are treated as if they had done nothing until this point in the countdown. This situation prevails only on the first Combat Turn. All subsequent turns begin, as usual, at the Base Action Phase of the character with the highest BAP.

When a character is in a position to surprise another character and thereby initiate Detailed Action Time, the controlling player may choose the Action Phase on which the countdown will begin in the first turn of Detailed Action Time. Once the phase is chosen the Combat Turn proceeds as if a character had pre-empted the situation and the preempting character's Base

Action Phase was the phase chosen by the player whose character has achieved surprise.

A surprised character may only use his Weapon Defense Ability if the phase of initiation is higher than the surprised character's Phases Consumed in Action number and the character makes a Speed Ability Saving Throw.

Crafty Old Sam is hiding in the shadows of an alley waiting for a victim. A figure appears and begins to move down the alley. Sam elects to let him pass and then jump out to attack. The player of Sam states that Sam will initiate this action on Action Phase 5 which is Sam's Base Action Phase. The Gamesmaster begins the countdown at 5. Sam's intended victim has BAP of 7 and MNA of 1. Thus, his PCA is 7 and there are not enough phases left in the Combat Turn for the character to get his Weapon Defense Ability into play. Since Sam began an Attack Action on 5, the victim is in engaged status. He must make a Deftness Ability Saving Throw in order to turn and face Sam. The Gamesmaster rolls 1D20 and the result is 17. This is well out of range for the character. On Action Phase 1 Sam will resolve his Attack action with the positive modification of 10 for attacking from a Rear hex. The victim can only subtract his Combat Dodge Ability from Sam's adjusted BCS.

On Phase 4 however, footsteps are heard in the alley. Two men begin to run towards Sam. They had been following the man who Sam is attacking. The Gamesmaster had secretly made a Wit Critical Saving Throw to see if Sam would discover the "Hidden Thing" of the two men. He did not. They could see Sam begin the attack on phase 5. Phase 4 was the first phase on which they could act in response to Sam's actions. By moving, they are using the rest of the Combat Turn to close the distance between themselves and the fight. Having started 10 meters from Sam on phase 4 they will be 3 meters away on phases 1. They will move 1 meter on Phase 4 and 2 meters per phase for 3 phases. Sam had better kill the first man when he resolves his Attack Action or he is in big trouble.

If a character should achieve complete surprise or execute a proper ambush, he should be allowed to perform at least one Action or move for a number of phases equal to his Phases Consumed in Action number. This would be followed by the normal Combat Turn routine with the countdown begun at its normal place.

This procedure represents the initiative gained by the ambushing character and his ability to take advantage of the situation. If desired by the Gamesmaster, this method may be used instead of the one given above.

THE DETAILED ACTION TIME DISPLAY

In order to keep track of the position of characters during Detailed Action Time, the players should use a DAT display. This will consist of a hexagonal grid sheet on which markers representing the characters are placed. The Display should also contain indications of features of significance to the characters, such as walls, doors, furniture, treacherous footing, etc. These indications can be in the form of additional markers or may be drawn onto the Display or a clear sheet covering the hex grid.

All characters should be represented by markers which may be moved on the Display. Anything small enough to fit in the hexes will do. We have found that miniature figures, painted to indicate the character depicted, add to identification with the character and to the general fun of play. If figures are not available a cardboard square marked to indicate which character it depicts is the second best choice. Remember that all markers used to represent characters must be able to denote which of the surrounding hexes is the character's central Front hex.

The recommended ground scale for the Display is 1 hex equal to 1 meter.

Sample Character Marker



THE CHARACTER ON THE DAT DISPLAY

Under normal circumstances a character on the DAT Display will occupy one hex and be able to exert influence on the six hexes immediately surrounding the hex he occupies. If the character is utilizing a Long or Extra-Long Hand-to-hand weapons, an additional ring of hexes around the standard Influence Zone must be considered. Those objects classed as Restrictions which are present in these zones will hinder the character in executing a successful attack. A character's Active Zone is considered to be the hex he occupies and any Front of Long Front hexes. A character's Passive Zone is any Rear, Side and Long Side hexes. The importance of these zones and the impact of the character's positioning on any combat in which he is involved will be dealt with in the appropriate sections.

Up to two active characters may occupy the same hex. Each will act as a Restriction to the other. Any other character making an attack into or through that hex has an even chance of striking either character. The one struck should be determined randomly.

A character in a horizontal position, for whatever reason, will occupy two hexes on the DAT Display. If he is conscious he will still have a Zone of Influence but it will be modified as shown in the accompanying illustration.

POSITION ON DAT DISPLAY MODIFICATION TABLE

WEAPON LENGTH	Target in		
	Long Front, Front, Side	Long Side	Long Side
Extra-Long	-1	0	0*
Long	-1	0	
Average	0	0	Not Allowed
Short	1	0	Not Allowed

* No secondary strike allowed.

Non-human species might not occupy the DAT Display in the same way as a human would. Variations will be indicated where the statistics for the species are presented.

Other Restrictions are counted if they are present in the character's zone of influence. Any solid object with a height of .5 to 1.5 meters can be

CHARACTER WITH A SHORT OR AVERAGE WEAPON

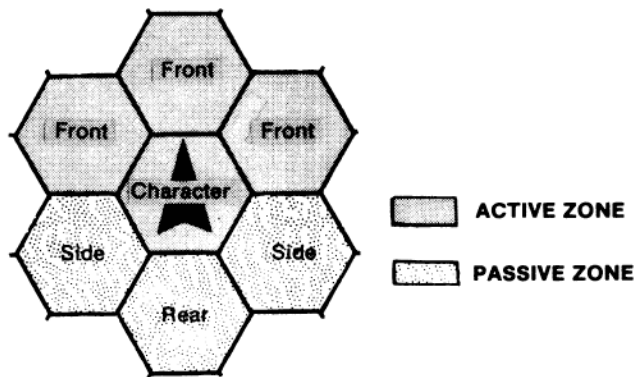

CHARACTER WITH A LONG OR EXTRA LONG WEAPON

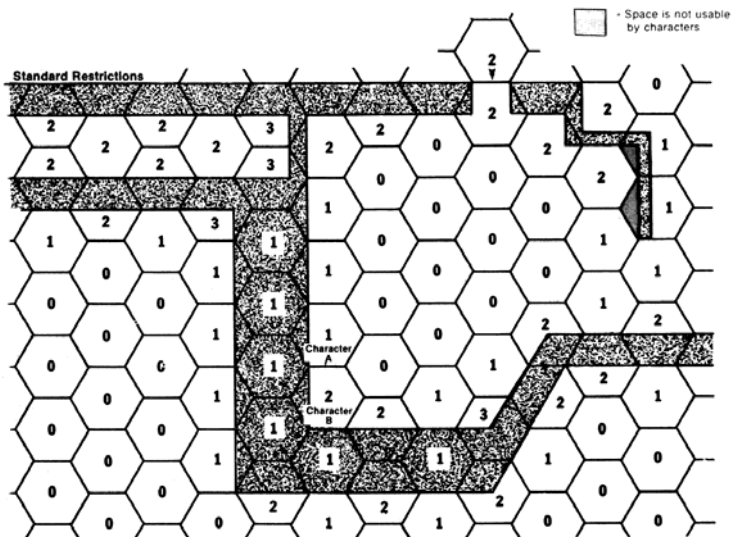
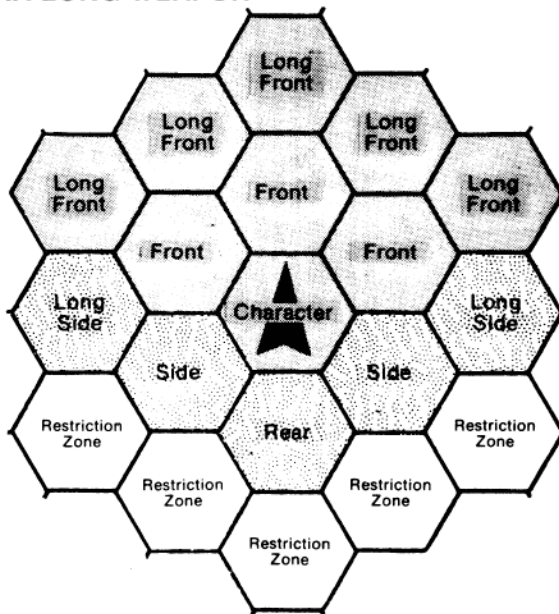

EXAMPLE OF LONG AND EXTRA-LONG WEAPON RESTRICTIONS

Character A
 Own hex Restrictions (1)
 Total Surrounding Restrictions (5)
 Restrictions on Long weapon (1 + 5/2 = 4)
 Restrictions on Extra-Long weapon (1 + 5 = 6)

Character B
 Own hex Restrictions (2)
 Total Surrounding Restrictions (6)
 Restrictions on Long Weapons (2 + 6/2 = 5)
 Restrictions on Extra-Long Weapons (1 + 5 = 6)

RESTRICTIONS AND DISTRACTIONS

The various components of the environment which will affect a character's Basic Chance of Success in combat are divided into the non-mobile, physical Restrictions and the mobile or non-physical Distractions. The former always apply while some of the latter may be voluntarily ignored.

The accompanying diagram illustrates the Restrictions imposed on a character in a given hex if he is using a Short or Average length weapon. These restrictions are only those posed by walls and doors. If the character were using a Long weapon, he would be subject to the restrictions of the space he occupies plus one-half of the total of restrictions in the hexes immediately surrounding him. In these circumstances, a hex which has no available floor space counts as 1 Restriction. A character using an Extra-Long weapon is subject to the Restrictions of the space he occupies plus the total of Restrictions in the hexes immediately surrounding him.

CHARACTER IN A HORIZONTAL POSITION

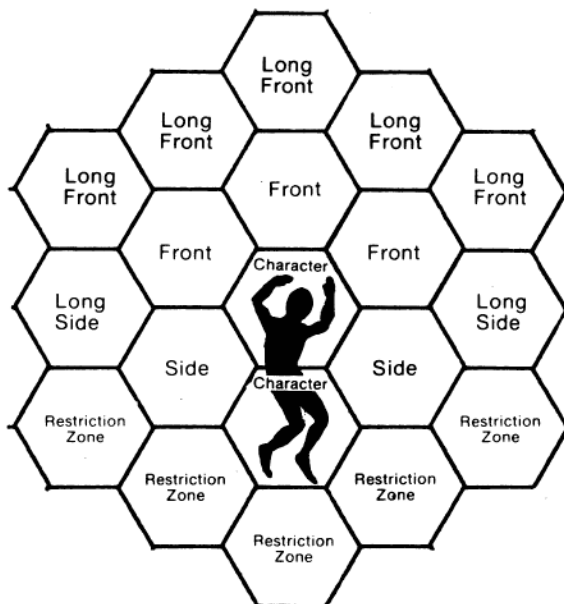

The large arrowheads indicate the central front facing of the character at the beginning and end of the Combat Turn. The smaller arrows indicate this facing on the Action Phases indicated by the numbers next to them. The dashed line indicates the path taken by the character in the movement undertaken during the Combat Turn.

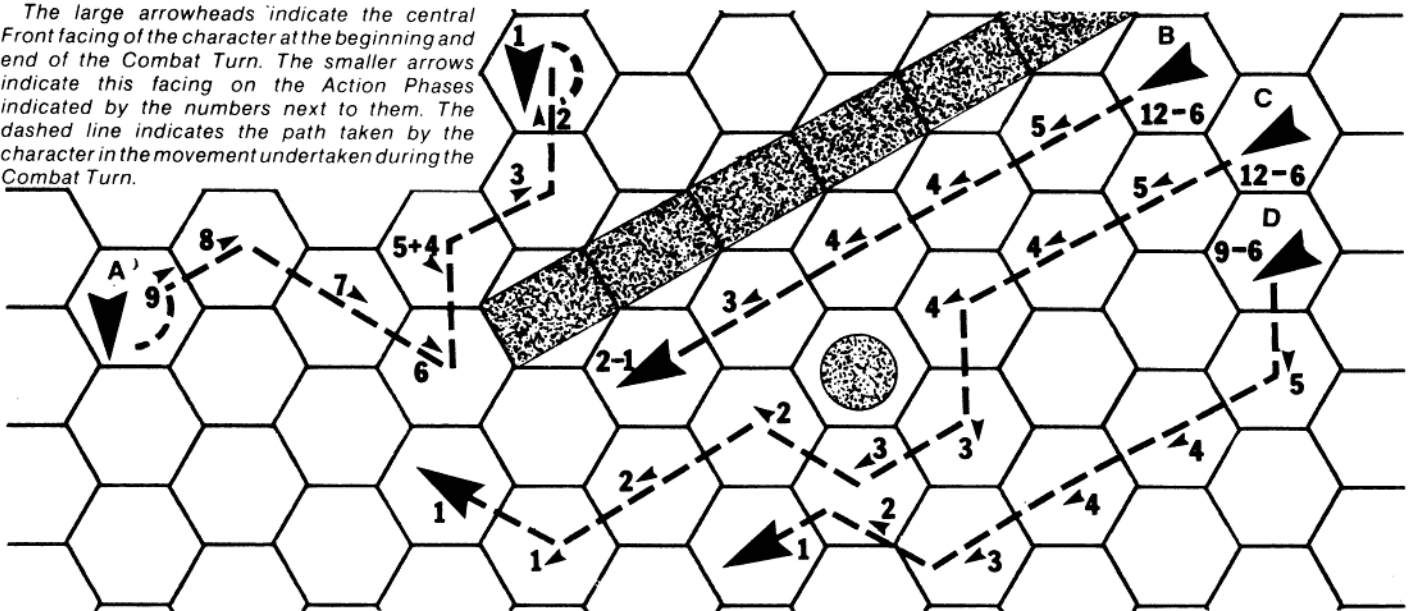

Characters B, C, and D are waiting for their opponent. Character A, to show himself. Characters B and C have a BAP of 12 and Characters A and D have a BAP of 9. Characters B and C make no movement on Action Phases 12 through 10. On Phase 9 Character A begins movement by turning in place by 120 degrees. The other characters continue to wait until Character A becomes visible to them. On Phases 8, 7, and 6 Character A moves forward to the edge of the wall. He is now visible to the other characters and they will react by moving toward him on the next phase.

On Phase 5 Character A begins to move to his left Side hex while "dodging" to make himself less vulnerable to missile fire. This will take two phases and will be completed on Phase 4. Characters B and C begin to move toward the edge of the wall. Character D moves out his left Front facing to gain room for the maneuvering to come. On Phase 4 Characters B, C, and D all accelerate to "run."

On Phase 3 Character A moves along the side of the wall away from his opponents. Character B decelerates to avoid running past the edge of the wall where his opponent might be waiting in ambush

for him. Character C continues around the column at a run. Character D decelerates to avoid a collision with Character C on the following phase.

On Phase 2 Character A moves away from the wall to have room to use weapons. Character B moves to a halt near the edge of the wall. While Character C continues his run around the column, Character D follows at a cautious walk.

Phase 1 finds Character A turning to face the direction from which he expects his enemies to come. Character B is waiting by the edge of the wall, not wishing to advance without enough phases left in the Combat Turn to perform a Combat Action and not wishing to move into a space where a hidden opponent might get a free attack. Character C continues his run to swing wide of the edge of the wall to avoid an attack by being too far from a hidden enemy at the edge. Since he has run on Phase 1, Character C must move on his first available phase of the next Combat Turn. Character D continues to move slowly ahead. At the end of the Combat Turn, Character C has passed into Character A's line of sight.

Base Movement allowance of 1 can move 12 hexes in a Combat Turn.

A Character may change his facing by spending one Action Phase doing so. When this is done while in Engaged Status, the character must make a Deftness Ability Saving Throw or suffer a "free attack."

A character has the option of "running" while moving on an Action Phase. This means that he will be able to travel twice his Base Movement Allowance in a given Action Phase. If a character elects to "run" at any point in the Combat Turn, he will be subject to the rules governing the stopping of forward motion given in section on page 24.

In order to be able to "run" the character must have moved either at "walk" (normal BMA) or a "dodge" on the previous Action Phase.

Additionally a character may opt to "dodge." This will add to his defensive capacity with regard to missile weapons but will reduce his Base Movement Allowance by one-half. A character may "dodge" while using normal movement or while "running."

A character may move sideways or backwards. When doing this the figure on the display is placed in the Side or Rear hex at the direction of the controlling player, but the relative facing of the character is not changed. Each time in one turn that the character's accumulated movement in a sideways and/or backwards fashion exceeds his Combat Dodge Ability (explained in the section on combat) he must make a Deftness Ability Saving Throw or fall. This accumulated distance is in hexes covered and is only accumulated through each separate Combat Turn.

A character performing an Action may move 1 meter in any direction without being subject to falling. It should be noted that this one meter of movement is all the movement that the character is allowed to make during the phases in which he performs the Action. This one meter of movement may be taken on any one phase of the phases during which the character is performing the Action and allows a sixty degree change of facing. Specific Actions may have variations on these general rules.

considered a Restriction. Each hex occupied by an object such as a table, chair or pillar has an additional Restriction of 1.

Dead or unconscious bodies in the character's own hex count as 1 Restriction each. Bodies may be stacked up to three high in an adjacent hex before becoming a Restriction.

The main source of Distractions is the occupation of hexes in a character's Zone of Influence by friendly characters or friendly characters within 1 hex of the line of fire. Each hex so occupied counts as 1 Distraction. This type of Distraction may be voluntarily ignored; by doing so the character will receive no negative modifications to his Basic Chance of Success. This course can be dangerous. If such Distractions are ignored, a Critical Miss, which would normally have had no effect, will automatically strike one of the friendlies. The exact target should be determined randomly and damage done should be calculated as for a normal successful attack. If a normal miss occurs, the number of friendlies ignored is the chance in 10 that the character must execute an attack against one of the friendlies who is determined at random. This attack is a "free attack" and is subject to all normal positional and situational modifiers.

Other Distractions are highly variable. They should be adjudicated by the Gamesmaster. He should decide if they are present, what value they have, whether they can be ignored and, if so, the consequences of ignoring them. Examples of Distractions include objects flying at a character, things hampering a fighter by crawling on him or things grasping a character.

MOVEMENT

The basic rule of movement in Detailed Action Time is that a character may move a distance equal to his Base Movement Allowance on each Action Phase in the countdown beginning with his own Base Action Phase. This movement is through one of the hex sides between the hex the character is in and one of his Front Hexes. Once the character has entered a new hex his facing will be adjusted so that the hex he has just vacated will be his Rear hex. This means that a character with a Base Action Phase of 12 and a

CONTINUITY OF MOTION

Any character who moves on Action Phase 1 of a Combat Turn will be considered "in motion" on his Base Action Phase of the following Combat Turn. This is primarily of concern for stopping of forward motion and for missile fire directed at the character before his Base Action Phase.

A character who completes a Combat Action on Action Phase 1 of a Combat Turn is considered in motion for purposes of any missile fire directed at him before his Base Action Phase. Note that this means that a character performing a Combat Action such as Attack or Defend is always considered in motion with regard to missile fire directed at him.

STOPPING FORWARD MOTION

Once a character has exceeded normal movement speed or has begun "dodging," he is subject to the following conditions. He must continue moving for the distances and times as required in the table below. This movement is mandatory and must be made into a Front hex. Obstacles in the character's path may have a deleterious effect on the character.

A character who makes a Speed Ability Saving Throw will reduce the additional movement required by one category. A character riding an animal must make his Beast Riding Basic Chance of Success roll AND the animal must make its Saving Throw in order to reduce the requirement by one category.

A character must stop his forward motion before initiating an Action. The one meter of movement allowed during an Action may not be used to stop forward motion. A character who is at the last stage of stopping and makes his Saving Throw may move a meter and initiate an Action.

STOPPING FORWARD MOTION TABLE

- Category 3:** achieved by running for a full Combat Turn or Charging. Character must move on a number of phases equal to his PCA at his normal BMA after which he will be at category 2. All movement must be out of the central Front hex.
- Category 2:** achieved by moving at a dodge-run or by reduction from above. Character must move one phase at his normal BMA after which he will be at Category 1. All movement must be out a Front hex.
- Category 1:** achieved by moving at a dodge or a run or by reduction from above. Character must move for one phase at his normal BMA after which he will be at Category 0. All movement must be out a Front hex.
- Category 0:** achieved by moving at a walk or by reduction from above. Character is subject to normal rules for movement in DAT.

CHARGING

In order to be eligible for charging benefits, the character or his mount must have moved for a minimum number of phases equal to 10 minus his Speed Group at a "run." This movement must be essentially in a straight line but the Gamesmaster may, at his discretion, allow deviations in the path due to circumstances such as a character attempting to charge to the intersection with the path of another character. Naturally such intent must be made known to the Gamesmaster, although he may or may not reveal it to the second character. (Is he watching the first character or is he too busy running?)

Obstacles in the way of a charging character will be subject to a Bash (see page 31). A successful Bash against the charger or an unsuccessful Bash against the obstacle will break the charge and subject the charger to the rules for stopping forward motion. Each such successive result will reduce the stopping category by 1. If the charger wishes to continue to charge he must satisfy the conditions for a charge as if he were starting all over again. If the obstacle to the charging character is a weapons set against the charge and the character controlling the set weapon makes his BCS roll for the weapon Skill, the weapon will have its chances for a special effect doubled and the charger will be subject to a Bash with a chance in twenty equal to his own effective Mass. If the set weapon has a longer effective length than the charger's weapon, this will occur before the charger can attack. If not, the charger's attack will be resolved first.

MOVEMENT THROUGH OCCUPIED HEXES

Normal movement through an occupied hex may be opposed or unopposed. Any attempt to move through an occupied hex at greater than normal movement speed is automatically opposed. If the movement is

opposed, use the Deliberate Knockdown rules on page 31. The opposing character gets the normal chances at a "free attack" as explained in the sections on Entering and Leaving the Zone of Influence. If the movement is unopposed, both characters are required to make a Deftness Ability Saving Throw. Success means that the character making his roll has no problems. Failure indicates that the character is prevented from moving or initiating an Action for a number of phases equal to his Phases Consumed in Action number. Critical failure indicates a fall by the character rolling the twenty and a second Saving Throw is required of the other character.

TREACHEROUS GROUND & MOVEMENT

A character moving on Treacherous Ground using "dodge," "run," or "dodge-run" type movements puts himself in danger of slipping. The former two options each give the character a 1 in 20 chance while the "dodge-run" option yields a 2 in 20 chance. For each phase spent in this motion the chance of a slip is increased by the basic chance. Thus, after three phases at a "dodge-run" a character has a 6 in 20 chance of slipping. The die roll for a slip is made on each phase.

Once a slip is indicated, the character must make a Speed Ability Saving Throw to avoid a fall. If the Saving Throw is made, the character is automatically considered to be "dodging" on the next phase and he will move one meter. This is involuntary movement and no actions may be attempted. If this causes the character to enter an enemy's Zone of Influence, the enemy will be allowed a free attack. The involuntary movement does not require a check for slipping.

When the character has had a Saving Throw to make and is able to continue movement, the chance of slipping is reduced to the basic chance and will be increased again if the character had just started movement.

Albert is running on Treacherous Ground. On his Base Action Phase of 10, he starts. A die roll of 4 on 1D20: no slip. On phase 9, his chance is 2 in 20 for a slip, The die roll is 1. He makes his Speed AST. On phase 8 he involuntarily moves forward 1 meter. On phase 7 he continues to run. His chance of slipping has been reduced to 1 in 20. The die roll is 12 so he is safe. On phase 6 he changes pace to a dodge-run. His chance of slipping is 3 in 20 and a die roll of 16 leaves him safe. He continues on phase 5 and the chance is up to 5 in 20. A die roll of 4 indicates a slip. This time he fails his Speed AST and falls. He must make a Health Saving Throw. The die result is in his Ability Saving Throw range so he will be Dazed until phase 5 on the next Combat Turn. His phases Consumed in Action number is 5 so he can not execute an Alter Position Action to get up this Turn. He decides to crawl forward for the rest of the turn. This does not require any checks for slipping but his Base Movement Allowance is reduced to .5. During the next four phases he will cover 2 meters.

CLIMBING IN DETAILED ACTION TIME

Under some circumstances it will be important to know how fast a character can climb a given distance. The effects of climbing, broken down by the method of climbing or the surface being climbed, are given in the table below. As a general rule, a character may not "run" while climbing although he may "dodge."

Sheer or almost sheer surfaces require Climbing Skill to negotiate. The Gamesmaster should roll at the beginning of the character's movement, If the character does not make his BCS roll, he will slip at some point in the turn. The Gamesmaster can roll a die with a range equal to the character's Base Action Phase to determine which phase of the turn the slippage will occur. If the character's Base Action Phase does not fit in one of the ranges normally covered by a die, the Gamesmaster should use the next highest range and reroll if the result falls outside the range under consideration.

If the character is operating under safety precautions when the slippage occurs, they will take effect. Characters who are roped to a secure position in the climbing surface will not fall further than the length of rope attached. Characters roped together when one falls will have to make a Strength Ability Saving Throw to keep their grip when the character on the rope next to them falls. This Saving Throw will be reduced if the total mass of falling character(s) exceeds their own Mass. The extent of the reduction is left to the Gamesmaster.

A character climbing by rope or ladder will have a chance to make a Deftness Ability Saving Throw to grab the ladder again. The character who is successful in doing this will lose one meter of height and be unable to perform any other Actions till the end of the Combat Turn or for a number of phases equal to his PCA number, whichever is shorter.

CLIMBING MOVEMENT TABLE

Method or Surface	BMA	Notes
Simple	.1	Maximum height in meters equal to Strength CST

rope		plus Strength Group Effect Die roll. Requires two hands. No other Actions allowed.
Knotted rope	.1	As above but substitute AST for CST. BCS modification of 2 while on ladder.
Ladder	.25	Treacherous Ground.
Stairs	.5	Treacherous Ground. "Running" allowed.

A character able to engage in combat while climbing must average his BCS in the Combat Skill in use with his BCS in Climbing Skill to get an effective BCS. This will then be subject to normal Restrictions, Distractions, Situational and Combat modifiers.

ENTERING THE ZONE OF INFLUENCE

A character entering any hex of the Active or Passive Zones of a hostile character who is capable of attacking is subject to a "free attack." Characters who are stunned, unconscious or otherwise physically incapable of attacking are not allowed "free attacks." Actions normally preventing an attack by the character still allow him to make a "free attack." Additionally, a character who enters that hostile character's Active Zone must cease movement for that Combat Turn. A character entering these Zones under the influence of the rules for stopping forward motion may be subject to multiple "free attacks" for each hex entered but he is not subject to the rule requiring cessation of movement. (He is not really in control, so he cannot stop when he enters the danger area, unlike the rational man assumed by the basic rule.)

There are ways of avoiding "free attacks" and moving within a hostile character's Active and Passive Zones, but they are not accomplished using the standard rules of movement. As explained in the section on Performing Actions, a character may make a one meter move while performing an Action. This one meter move, which is the only movement allowed during a number of phases equal to the character's Phases Consumed in Action number, may be referred to as a Combat Move. If the character entering a hostile character's Active or Passive Zone is making a Combat Move, he is not subject to a "free attack." By making Combat Moves, the character may move through the hexes of the hostile character's Active and Passive Zones without incurring a "free attack." The character may continue to move in this fashion as long as there are sufficient phases remaining in the Combat Turn for him to perform Actions.

ENGAGED STATUS

A character who is in the Active Zone of a hostile character who is capable of attack, is in Engaged status. It is important to note that some Actions can not be undertaken while Engaged. Others will require a Saving Throw to complete. Still others, particularly actual combat Actions, are under no penalty.

PERFORMING ACTIONS

When the character wishes to do something other than simply move during the Combat turn, he must perform an Action. Simple Actions require a number of Action Phases to complete equal to the character's Phases Consumed in Action number. If there are insufficient Action Phases Consumed in Action number. If there are insufficient Action Phases left in the Combat Turn for the character to complete the Action, it may not be initiated in that Combat Turn. More complex Actions will require the character to continue performing the Action at successive opportunities which may go on for several Combat Turns before enough time has been spent to resolve the Action.

The basic rule for resolution of an Action is that it will be rolled for on the last of the Action Phases consumed by its performance. An Action initiated on Action Phase 7 by a character with a PCA of 3 will be resolved on Action Phase 5. The same character can not initiate an Action after Action Phase 3, although he could still move subject to normal movement rules.

A character performing most Actions is allowed a one meter move. This move may be in any direction and may involve a facing change of 60 degrees. When in, entering, or leaving the Active of Passive Zone of a hostile character, this movement is known as a Combat Move. This may take place on any phase during which the Action is performed. Certain Actions allow no movement and these will be specified as they arise.

The resolution of an Action usually requires the rolling of a Basic Chance of Success die roll, if a Skill is in use, or of a Saving Throw, if an Attribute is being put to use.

SIMPLE ACTIONS

Most of the simple Actions are involved with combat, while more complex ones are usually not directly related to combat.

Attack — This Action is used for armed and unarmed Hand-to-hand combat utilizing an appropriate Skill for the character. This Action may only be initiated if an opponent is already in range or the character's Combat

Move will bring the opponent into range when initiating the attack. If the opponent leaves the Zone of Influence of the character before the attack is resolved and the character cannot move to keep the opponent in his Zone, the attack is resolved on the phase on which the opponent moves. The character may not move or initiate another action until the usual Phase.

Defend — This Action allows the character to increase his Weapon Defense Ability to 1 50% of its normal value for the duration of the Action. No attack allowed.

Fire Weapon — This Action is required when using missile of any kind if negative modifiers due to motion are to be avoided. Muscle-powered weapons resolve at the end of the Action, and single-shot non-muscle-powered weapons in the middle, although the character may not move or initiate another action until the usual phase. Multiple shots are spaced as evenly as possible through the available phases used by the Action. In these cases, fractional values should be rounded down. This Action requires a Deftness Ability Saving Throw while Engaged.

Reload Weapon — The number of times this Action must be performed before the weapon is ready to fire again will vary by weapon type. This Action requires a Deftness Ability Saving Throw while Engaged.

Exchange Weapons — This Action covers the return of a weapon to its holster, sheath, or carrying place and the drawing of a new one. Some pieces of equipment (shields, polearms, etc.) may require longer and this is adjudicated by the Gamesmaster. A weapon can be voluntarily dropped without difficulty in the space of an Action. This Action requires a Deftness Ability Saving Throw while Engaged.

Survey and Command - This Action allows the character to observe what is going on around him. Normally a character will observe only what is in front of him. This Action also allows the character to make a short coherent statement to other characters without using the normal rules for communication in Detailed Action Time. This Action may not be performed while Engaged.

Jump — This Action allows the character to execute a jump under the following restriction: To qualify for a running version of a jump the character must satisfy the conditions of charging. The character does not get the normal one meter move associated with an Action. The character may add the result of a Strength Group Effect Die roll to his Current Strength for the distance calculation if he makes a Strength Critical Saving Throw.

Vertical, standing	STR AST/(6 x Mass), up
Vertical, running	STR/(9 x Mass), up

These distances are in meters above the character's head.

Broad, standing	STR AST/Mass, up
Broad, running	STR/mass, up

These distances are in meters.

The Gamesmaster can calculate the distance covered during each phase in the character's Action by dividing the total distance covered by the character's PCA number. Players should be required to commit their characters to jumping before they roll the Critical Saving Throw to see if they will get any extra distance.

Alter Postion — This Action is performed when a character changes position from prone, kneeling or sitting to standing. It is also used when a character changes position from standing to prone and used thus eliminates the necessity for the character to a Saving Throw against winding himself. A character not using this Action to go prone is subject to the rules for falling. No movement on the DAT Display is allowed. The character is assumed to stand in the hex in which his feet are located. During the phases in which the Action is performed a character is considered moving for the purposes of any missile weapons targeted at him. This Action requires a Speed Ability Saving Throw if utilized while Engaged.

Perform a Function — This Action allows the character to apply any Skill other than a Combat Skill. As with Reloading, the number of times the Action must be applied will vary. This should be adjudicated by the Gamesmaster.

Reloading, drawing or sheathing a weapon, and such other simple functions as are allowed by the Gamesmaster may be attempted while moving instead of using an Action to perform them. At the phase on which the character would have resolved the Action, the character must make a Deftness Saving Throw in order to be successful. The level of the Saving Throw and any modifiers to it are at the discretion of the Gamesmaster.

THE LAST SHOT OPTION

If a character who has a loaded and ready missile weapon finds that he is going to be put in Engaged status by another character before his Base Action Phase, the missile-armed character may elect to fire using the last shot option when the character who is closing in on him enters the Point

Blank range for the weapon. This shot will be resolved at that point. The character who elects this option will thereby already be committing himself to a Fire Weapon Action as the next Action he undertakes. He must begin it on his Base Action Phase. He essentially does nothing because his Action has already "occurred." The missile firing character will receive a modification to his BCS equal to the difference between the phase that the shot is resolved on and his Base Action Phase.

The last shot option does not apply to characters who initiate a Fire Weapon Action and who will be Engaged before their shot is resolved. If they are in Engaged status by the time the phase for resolution arrives in the countdown, a Dexterity Ability Saving Throw is required for the character to be able to get off the shot. If the character's planning allowed an enemy to get that close at that point in time, the character must pay the price.

FIRING WHILE MOVING

Characters using guns and crossbows are allowed to fire while moving. Shots are spaced as if the character had used a Fire Weapon Action. All shots are subject to the hip fire penalty and an additional penalty based on movement. For specifics see the Gun rules in Book 2.

COMMUNICATION IN DAT

Once DAT is begun characters must utilize appropriate Actions to communicate information among themselves. To simulate the confusion and independent action common to people in stress situations the Gamesmaster should rigidly enforce these communication limitations. It gives a more realistic result than allowing the players ten minutes to coordinate actions which will be happening in a game time frame of six seconds. Such attempts on the players' part should result in the tactical discussion by the players being taken out of DAT and put into Real Time where such discussion is timed and added to the game time that the players are consuming.

The Survey and Command Action allows the greatest freedom of communication. The player should be allowed to communicate a coherent sentence. Most other Actions will allow a character to communicate one word per phase. When the character is, in one phase, moving distances greater than his base BMA much more than one or two words should not be allowed for each PCA period of phases. The player may state whether such communications are shouted, spoken or whispered. The Gamesmaster should be careful to take into account prevailing conditions and how they will affect the stated communication. Gunfire in a confined space is notorious for putting a damper on polite conversation.

COMBAT PROCEDURE

The basic procedure for Combat is straightforward. The attacking character's Basic Chance of Success in the Combat Skill that is being applied is modified by Restrictions, Distractions, Situational Modifiers and the opponent's Defensive Ability. The player then rolls 1D20. If the number falls in the modified range the opponent has been hit. If not, he has been missed. Once the opponent is hit the player determines his Damage Potential while the Gamesmaster determines the Location of the hit. The Armor Value of the protection that the opponent is wearing is subtracted from the character's Damage Potential and the result is the damage applied to the opponent.

A die roll of 1 always hits except in the case of the "hopeless" attack. A die roll of 20 always misses. Under most circumstances these die rolls indicate a Critical Hit and a Critical Miss, respectively.

A flowchart of the combat procedures is provided in Appendix 2.

CONDUCTING AN ATTACK

To conduct an attack the player states to the Gamesmaster what Combat Skill the character is using and whether any secondary strikes will be attempted. This is done when the character initiates the attack. The primary strike (the only one if there is no secondary strike) uses the full Basic Chance of Success (BCS) and the secondary strike uses the average BCS.

This is the Base BCS.

The Base BCS if then modified by the Restrictions due to positioning on the DAT Display. It is further modified by any Distractions present. The above can be determined by the player. The player and Gamesmaster jointly determine if there are any situational Modifiers. This is done jointly because while some of the modifiers will be perfectly obvious, there may be modifiers, known to the Gamesmaster, of which the character is unaware. The Gamesmaster will then subtract the Overall Defense Ability of the defender. This yields the Adjusted BCS which is the number which the player must roll less than or equal to on 1D20 in order to hit the defender.

SITUATIONAL MODIFIERS

These Situational Modifiers are given as a guideline for the Gamesmaster in determining what kind of modifications should be made. It would be impossible to list all the potential situations that characters can get themselves into in the course of an adventure. It is up to the Gamesmaster, in the end, to determine what Situational Modifiers apply and their value. Discretion is advised.

SITUATION MODIFIER TABLE

HAND-TO-HAND COMBAT

SITUATION	BCS
Each Distraction	-1
Each Restriction	-1
Target is prone	+2
Attacker is prone	-10
Target is sitting or kneeling	+2
Attacker is sitting or kneeling	-5
Attacking to a Side or Long Side hex	-5
Attacking from a Side or Long Side hex	+5
Attacking to a Rear hex	-10
Attacking from a Rear hex	+10
Attacking from a superior position such as a table or stairs, etc	+1
Attacking from an inferior position such as the reverse of the above	-1
In Dim light*	-3
In Poor light*	-5
In Darkness or Partially blind*	-9
Totally blind*	-12
Attacker is over 50% wounded*	-2
Attacker is over 75% wounded*	-4

*These also apply when using missile weapons.

MISSILE WEAPONS

SITUATION	BCS
Hip fire	use Average BCS
Damaged in that Combat Turn	-(damage taken/2)
Firing a gun in each hand	-1 to all shots
Surprised	-2
Shooting at a newly acquired target	-2
In firing stance	+1
Braced weapon (requires firing stance)	+1
Sighted in (requires stance)	+1
Shooting out a side hex	-2
Shooting out a Rear hex	-4

THE "HOPELESS" ATTACK — ADJUSTED BCS LESS THAN 1

With an Adjusted BCS less than 1, the player must roll a 1 on 1D20 to have a chance to hit. If he does roll a 1, he must roll 1D20 again. If the second die roll is less than or equal to his Base BCS, he will hit his target. A 1 on the second die roll will indicate a Critical Hit.

ADJUSTED BCS EQUAL TO 1

In this case, a die roll of 1 on 1D20 requires a second roll of 1D20. If the second die roll is less than or equal to the character's Base BCS, a Critical Hit is scored. Otherwise the hit is only a normal hit.

ADJUSTED BCS GREATER THAN 1

This is the standard case. A die roll of 1 indicates a Critical Hit. A die roll less than or equal to the Adjusted BCS indicates a hit on the defender. Any other roll indicates failure to strike the defender. A die roll of 20 indicates a Critical Miss.

RESULTS OF A HIT

Once the player has made the appropriate die roll and the Gamesmaster has announced that a hit has been made, the Gamesmaster will determine the Location of the hit by rolling 1D100 and consulting the table and Location maps below. If the Location indicated by the die roll is considered to have a covering barrier between the attacker and it, the attack must penetrate the barrier before any results can be applied to the target. The effects of barriers on a gun's Bullet Damage Group and the effective Strength Group for other missile weapons and Hand-to-hand weapons are given on the section on Barriers on page 46. These modifications must be made before the Damage Potential may be determined.

HIT LOCATION TABLES

BIPEDAL

D100	LOC
1-4	1
5-8	2
9-11	3
12-20	4/5
21-29	6/7
30-38	8/9
39-47	10/11
48-53	12
54-59	21/22
60-65	23/24
66-69	25/26
70-74	27/28
75-80	29/30
81-86	13/14
87-93	15/16
94-98	17/18
99-00	19/20

MODIFICATIONS

Bipedal

from above	-5
from below	+5

Quadrupedal

from the front	-5
from the rear	+5

These values may be altered by the Gamesmaster as he sees fit. A long quadruped might have a modification of 10 rather than 5.

QUADRUPEDAL

D100	LOC
1-4	1
5-12	2
13-20	3/4
21-28	5/6/7
29-36	18/17
37-44	20/19
45-48	22/21
49-56	8/9/10
57-64	11/12/13
65-72	14/15/16
73-80	24/23
81-88	26/25
89-92	28/27
93-96	29
97-00	30

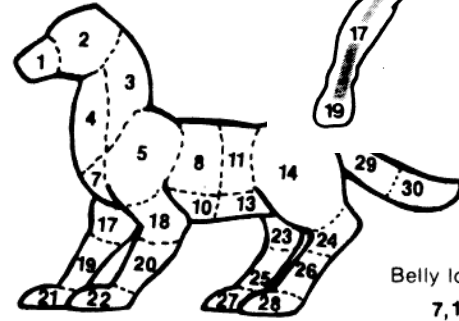
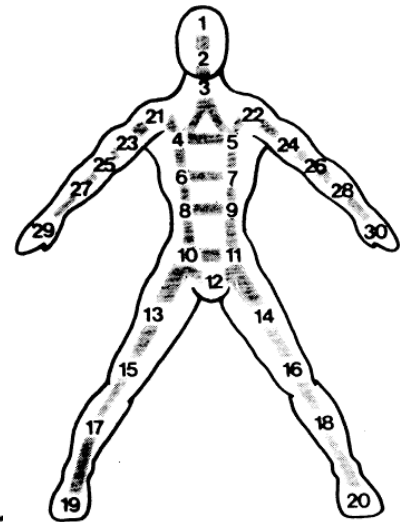

Belly locations are
7, 10, 13, 16

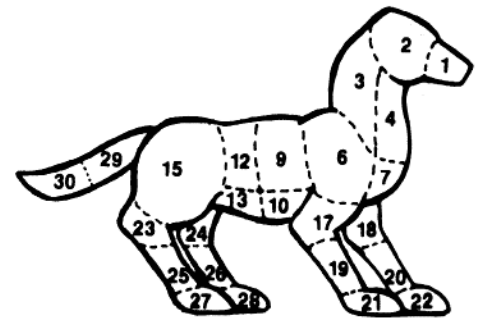

Where the location result gives more than one possibility for the exact result, 1D100 is rolled and the table below is consulted to give the exact location.

Attack from Front or Rear

X/Y	50% either location
X/Y/Z	1-40/41-80/81-00

Attack from Side

X/Y	1-70 nearest side/71-00 furthest side
X/Y/Z	1-60 nearest side/61-70 furthest side/71-00 underbelly

If the target is using a presented or refused positioning, treat attacks from the side as attacks from the front or rear and vice versa.

DAMAGE POTENTIAL

Once it has been established that a hit has been made, the player may determine the character's Damage Potential for that hit. If it is a Critical Hit, the normal Damage Potential is altered. The exact changes are dealt with in the section on Critical Hits.

The calculation of the Damage Potential will vary by the weapon system in use.

- **Hand-to-hand weapons** — Each such weapon is rated for a Weapon Damage Multiplier (WDM). Each character has an Effect Die in accordance with his effective Strength Group. The character's Effect Die is rolled and the resulting number is multiplied by the Weapon Damage Multiplier. The result of this calculation is the Damage Potential.
- **Guns** — Each round fired from a gun is rated for a Bullet Damage Group (BDG). The BDG of each round striking the same Location on the same Action Phase is totaled. This number is divided by 10. The resultant number when rounded up yields the number of D10s of

damage and the number rounded to the nearest is the addition to the number of points of Damage Potential rolled on those D10s.

Damage Potential equals

(BDG/10, up) in D10s + (BDG/10, nearest) in points of damage

- **Muscle powered missile weapons** — Each kind of weapon in this category varies and the specifics are given with the description of the Skill required to use the weapon. Basically, the Damage Potential is calculated as for Hand-to-hand weapons but Strength Group is modified for range rather than for position on the DAT Display.

It is important to note that if the adjusted Damage Potential does not exceed the Armor Value of the target Location, there is no Critical Effect due to a Critical Hit or a Missile Special Effect.

DAMAGE DONE

Once the Damage Potential and the hit Location is known, the actual damage done can be calculated. The Armor Value that the target of the hit has at the Location hit is subtracted from the Damage Potential to yield the Damage Done.

SYSTEM SHOCK

If the Damage Done exceeds the Shock Factor (SF) of the recipient, he is subject to a check for System Shock. To avoid System Shock, the character must make a Health Ability Saving Throw. If he fails he will fall unconscious for a number of Combat Turns equal to 50 -Health of the character.

The Shock Factor for humans is set at 10. Player Characters and Personality Non-Player Characters may add their Healing Rate to their Shock Factor. The Shock Factor for non-human species is given with their other statistics.

TYPES OF DAMAGE

Each type of weapon or damage-causing attack is rated for the type of damage caused. If there is no specification then the damage done is assumed to be Lethal.

- **Lethal (L)** — This is the type of damage done by edged and pointed weapons. Most weapons in this classification may be used to produce Crushing type damage when used with the "flat." When this is done the normal Weapon Damage Multiplier is halved.
- **Subdual (S)** — This type of damage is not immediately lethal in effect.
- **Crushing (C)** — This type of damage is done by weapons which rely on smashing power to cause damage. The actual Damage Done is 3 points of Subdual and 1 point of Lethal for every 4 points inflicted. That is, every fourth point inflicted is Lethal while the rest is Subdual.
- **Combination (B)** — This type of damage is done by massive weapons which has some edges or points such as spiked maces. The Damage Done is divided evenly between Subdual and Lethal. That is, every second point inflicted is Lethal while the rest is Subdual. Odd points are thus Subdual.

The effects of injury and the healing of damage are dealt with in the appropriate sections starting on page 36.

A fifth type of damage known as Critical Damage may result from a Critical Hit. This indicates immediate disabling damage. It is not added into the current total of damage.

IMPALEMENT

All thrusts have a chance of Impalement. The percentage chance is equal to the Damage Potential. If Impalement occurs the Gamesmaster will treat it as if a Missile Special Effect had occurred. See below.

MISSILE SPECIAL EFFECTS

Whenever a character is struck by a missile weapon there is a chance of a Missile Special Effect occurring. The percent chance of an occurrence is equal to the adjusted bullet Damage Group if the weapon is a gun and it is equal to the Damage Potential if the weapon is a muscle powered missile weapon. If the number rolled on 1D100 is less than or equal to the required number, than a Missile Special Effect will occur and the table below should be consulted.

Modifications to the Adjusted BDG in order to determine whether Missile Special Effects occur may arise due to the ammunition in use. Similar modifications may apply to muscle powered missile weapons. Such modifications will be presented with the description of the ammunition or weapon.

MISSILE SPECIAL EFFECTS TABLE D100 RESULT

1-20	No special effect
21-30	Flesh wound: damage is adjusted to 1 point and this only if the Armor Value on the target location is exceeded.
31-45	Minor wound: 1 point of damage caused. This supercedes any normal results. This effect on a Critical Hit results in normal damage.
46-65	Normal damage and Stopping.
66-75	As 46-65 plus a Daze effect (see Critical Hit Effect Explanations).
76-85	As 66-75 plus a Stun effect (see Critical Hit Effect Explanations).
86-95	As 76-85 plus a roll on the Critical Effect Table.
96-00	As 86-95 but add 30 to the roll on the Critical Effects Table.

STOPPING

The effect number for Stopping is equal to the Adjusted BDG (used to determine if a Special Effect would occur) or the Damage Potential for muscle powered missile weapons and Impalements divided by the Mass of the target.

IF > 1	Knock back for 2D3 meters. A Deftness Ability Saving Throw is required to prevent being knocked down. Each two meters of knock back will drop a target one category for purposes of stopping forward motion.
IF > 5	As above but a Critical Saving Throw is required for the character to keep his feet.
IF > 10	As above but knock down is automatic.
IF < 1	the % chance of getting a result as if the effect number were equal to 1 is the Adjusted BDG (used to determine if Missile Special Effects would occur) divided by the Mass of the target multiplied by 100.

CRITICAL HITS

When a Critical Hit has occurred the Gamesmaster will roll on the appropriate Critical Hit Enhancement Table to determine the increase to the Damage Potential.

CRITICAL HIT ENHANCEMENT TABLES

HAND-TO-HAND AND

MUSCLE POWERED MISSILE WEAPONS

D20	Enhancement	GUNS
1-9	+1 to WDM	Pistol +1D10 to BDG
10-15	+2 to WDM	Rifle + 2D10 to BDG
16-19	+3 to WDM	Burst All rounds hit plus
20	+4 to WDM	the effect of 1D3
		additional rounds.

Once the Damage Done is calculated, the Gamesmaster will roll on the Critical Effect Table if the Damage Potential has exceeded the Armor Value of the hit location. The Gamesmaster should add the Damage Done to the D100 that is rolled to determine Critical Effect.

CRITICAL EFFECT TABLE

D100	EFFECT
1-30	No special effect.
31-55	Daze.
56-75	Stun.
76-87	Disable.
88-95	Trauma.
96-00	Lethal.

DAZE — The character's BCS and ODA are at 1/2 value until after the Action Phase on the next Combat Turn which has the same number as the phase on which the effect occurred.

STUN — As above but the character may not initiate any attacks or fire any weapons. Additionally the character's Deftness and Speed are reduced to ½ value for that time period and the character will be treated as Dazed for the following Combat Turn.

DISABLE — This is a numbing effect. If received in a limb, the character will lose the use of that limb for the rest of the combat. Health Ability Saving Throws may be made each hour of game time in order to regain use of the limb.

If received in the head, neck or body the character must make Health Saving Throw. Failure indicates a System Shock. A save in the Ability range means the character will be Stunned for the rest of the combat. A save in the Critical range means that the character will be Dazed for the rest of the combat. A Health Ability Saving Throw can be attempted each hour of game time in order to eliminate these effects.

TRAUMA — The Damage Done is Critical Damage. The also receives one half the Damage Done as regular Lethal damage. A Health Ability Saving Throw is required or the character also receives a Disable Effect.

The Critical Damage is also the percent chance of a Sever Effect. Severs to the head or neck are Death Blows. All other Severs will cause the character to bleed to death in a number of Combat Turns equal to the character's Health Group plus 1D6 unless cauterized or bandaged with a First Aid Skill BCS roll. Cauterization will automatically put the character into System Shock. A Health Ability Saving Throw is required for the character to survive the cauterization.

Sever results due to things which do not cut are considered to have broken the bone. If the character fails a Health Ability Saving Throw, the result will be a compound fracture and he will be subject to bleeding to death, as if a normal Sever result had occurred.

LETHAL — **To head, neck or torso:** Death. **To a limb:** Automatic Sever.

Player Characters and Personality Non-Player Characters are allowed a Health Ability Saving Throw to lower the Effect to the next less lethal category.

CRITICAL MISSES

When the die roll for any attack is 20, there is a chance of a Critical Miss. The Gamesmaster will request that the player make a Control Throw for the character to avoid a Critical Miss. If the Adjusted BCS of the attack exceeded 20, the number required for the Control Throw may be increased by the Adjusted BCS minus 20 at the discretion of the Gamesmaster. Such circumstances will; at least with Hand-to-hand and muscle powered missile weapons, allow a Control Throw for a character who would not normally have one. If the character fails the Control Throw, the appropriate Critical Effect Table should be consulted.

If a character is ignoring the distraction of friendly characters, in his Zone of Influence if using Hand-to-hand weapons or in the line of fire if using missile weapons, the result that normally indicates no Critical Effect means that he has automatically scored a successful hit on one of the friendly characters who qualified as a Distraction. The character to be struck should be determined at random.

CRITICAL MISS EFFECTS TABLES

ARMED COMBAT

D100	RESULT
1-10	No effect.
11-40	Character is Dazed.
41-70	Character is Stunned.
71-80	Character falls.
81-90	Weapon breaks.
91-00	Character drops weapon.

UNARMED COMBAT/NATURAL ATTACK

D100	RESULT
1-10	No effect.
11-40	Character is Dazed.
41-70	Character is Stunned.
71-80	Mode of attack (hand, foot, jaws, etc.) receives a Disable result with 1D6 of Critical Damage.
81-00	Character falls.

BOW AND CROSSBOW

D100	RESULT
1-10	No effect.
11-40	String breaks.
41-80	Arrow breaks.
81-00	Bow breaks.

FIREARMS; BLACK POWDER

D100	RESULT
1-10	No effect.
11-40	Primer flash. Primer is expended but the round is still good.
41-70	Main load is a dud. Primer and powder for round are expended. Gun must be reloaded.
71-85	Cook-off. Appears to be a dud round. twill goofon the bookkeeping phase. There is a 50% chance of it going off if there is an attempt to remove it before Action Phase 0. If it goes off, treat as if it were a chamber explosion as below.
86-95	Chamber explosion. Burst effect of BDG of the round/30, nearest. Burst effect minus the Durability of the weapon is the number of D10s of Lethal Damage done to the character's Location that is nearest to the breech of the gun. If the number of D10s is less than 1, reduce the Durability of the gun by 1 and treat as if the

main load was a dud. If the number is greater than or equal to 1 (the chamber actually does explode), the gun is Disrepaired with a chance (equal to the number of D10s) in 6 of it being Junked. Chamber explosion as above but burst effect is BDG of the round/20, nearest.

FIREARMS, MODERN

D100 RESULT

1-10	No effect.
11-40	Dud round. Autoloaders and autoweapons require 1 Action to manually clear the round. Other types clear with the next round, no special action is necessary.
41-70	Jammed round. Requires 2 Actions to clear manually. A weapon with an extractor will clear in 1 Action.
71-85	Cook-off. See Black Powder firearms.
86-95	Chamber explosion. Burst effect is BDG of the round/30, nearest.
96-00	Chamber explosion. Burst effect of the round is BDG/20, nearest.

GENERAL NOTES ON COMBAT PROCEDURE

The preceding provides a basic guide to the procedure for combat. Certain details involving particular weapon systems are presented in the section where the weapon is discussed. This has been done to maintain the flow of the explanation of combat in general and to keep pertinent information that is peculiar to a given weapon system in one easy-to-reference place. Players are strongly encouraged to be familiar with the mechanics covering the weapon systems that they choose for their characters as this will make the Gamesmaster's job easier. Fledgling Gamesmasters should also be advised not to have non-player characters using weapon systems that the Gamesmaster is not ready to handle. It will slow play tremendously.

Other details of certain forms of combat, as well as combat and movement in other environments, are also dealt with in separate sections for similar reasons. These include such things as horses and mounted combat, swimming and in or under water combat, and specific sections dealing with optional additions to Detailed Action Time combat.

OPTION "THE CLASH OF WEAPONS"

This section deals with the circumstances arising when an attack fails to strike the opponent himself and is only stopped by his skill with the weapon system he is using to defend himself. The basic mechanic works as follows: the last thing to be subtracted from the attacker's Base BCS is the opponent's Weapon Defense Ability. If the player's die roll is such that, if the Weapon Defense Ability had not been subtracted from the Base BCS to give the Adjusted BCS, it would have indicated a hit, it means that the opponent used his weapon system to stop the attack. The significance of this will vary due to the weapon system actually used for defense. A character using Weapon and Shield Skill will have the shield struck in these circumstances. A character using a Skill involving a weapon will have the weapon struck. A character with two weapons will have the secondary weapon struck. A character using a Skill without a weapon will take the blow on the forearm (usually of his offhand arm).

WEAPONS — The difference between the weapons Survival Values is the chance in twenty that the weaker weapon will break. A character may continue to defend with a broken weapon but his Weapon Defense Ability will be halved, rounded down. Attacks with a broken weapon are not allowed.

A weapon's Survival Value is the sum of two factors. One is based on the weapon's size and the other on its construction. The second is a number equal to the Armor Value of Plate in the corresponding material. Wood has a value of 3 and reinforcing it with metal will increase its value according to the normal reinforcing rules for armor. The factor based on size can be gotten from the accompanying table.

Weapon	Size Factor
Close	0
Average	1
Long	2
Extra Long	3

SHIELDS — If a shield is struck by a missile weapon, the shield user must make a Dexterity Ability Saving Throw. or the weapon will become lodged in the shield and add to the Encumbrance of the shield. Bullets will reduce a shield by one class if the Effective BDG exceeds the overall Barrier Effect of the shield by three times its value. Muscle powered missile weapons and Hand-to-hand weapons will reduce a shield by one class if the Damage Potential, when generated as if a hit had been scored, is greater than the overall Barrier Effect of the shield.

THE BODY — If the striking weapon's Survival Value exceeds the Armor Value on the Location of the block the target character will receive the difference in Lethal damage.

Missile weapons are only germane to shields as they cannot be defended against by Weapon Defense Ability. Some shields do have an add to the Overall Defensive Ability and this addition functions as Weapon Defense Ability under these circumstances.

BASHING

When a greater effective mass strikes a lesser, a Bash may occur. This can occur from a large animal striking a human, a human striking a smaller animal, a charging horseman striking or overrunning an opponent, etc. The chance in 20 of a Bash occurring is equal to the larger effective mass minus the smaller. If the Bash occurs, this same difference is used as an effect number and the Bashed character is treated as if he had received Stopping from a Missile Special Effect.

OPTION SPECIAL EFFECT

In human-to-human combat, the Gamesmaster may allow a Bash to occur if the character has successfully hit his opponent and the attacker's Mass plus his weapon's Size Factor (see above) exceeds his opponent's Mass. The difference would be the chance in twenty of a Bash occurring.

DELIBERATE KNOCKDOWN

A character may deliberately attempt to knockdown another character. This is accomplished by moving into the hex occupied by the second character and comparing the Strength Group Effect Die rolls of both characters. The character with the greater effective Mass may add the difference in the masses to his die roll. The difference in the modified die roll results is treated as an Effect Number and the lower rolling character receives a Stopping Result. If the Effect Number is 0 then the characters are occupying the same hex. Each will be unable to perform an Action for a number of phases equal to his Phases Consumed in Action number or until the end of the Combat Turn whichever is shorter.

In any case, if the second character was in the process of performing an action, he will resolve that Action at the usual time with a negative BCS modification equal to the Effective Mass of the character attempting to knock him down.

GRAPPLING

Grappling is a form of rough and tumble, close-in fighting. A character does not need to exercise a Skill in order to Grapple. A Deftness Ability Saving Throw is required to perform a Grapple. If the player rolls a 1 when making the die roll, he may choose the general location of the Grapple. If the Grapple attempt fails, the player must make another Ability Saving Throw; this time using Speed; to avoid having the character fall down. If the player rolls a 20 on the Grapple attempt, the character automatically falls down.

When a Grapple attempt is successful, the Gamesmaster will roll for Hit Location as if a normal hit had been scored. The exact Location and the General Location are both of import. That is the head, neck, torso, right or left arm and the right or left leg is of significance, as well as the exact Location on the body map.

A Grapple to the arm will allow an attempt to disarm the target. The Grappler will roll the Effect Die for his effective Strength Group. The target's Armor Value on the exact Location is subtracted from the die roll. The result is the chance in 20 that the target must make a Strength Ability Saving Throw in order to retain his grip on whatever he is holding in his hand. If the target makes his Saving Throw, the grapple is not broken and the Grappler may roll his Effect Die again at the end of his next Action unless he initiates a new attempt to Grapple in the hope of getting a Grapple on a more useful Location or he initiates some other Action.

A Grapple to the leg indicates a takedown attempt. Each characters will roll their Effect Die. If the Grappler rolls higher, the target will fall down. If the target rolls higher, there is no effect. If both roll the same number, each must roll a Speed Ability Saving Throw to avoid falling down. The Grappler is not considered to have maintained a hold on the target at the end of a takedown attempt regardless of its results. He must initiate a new attempt to Grapple on his next Action, if he wishes to continue in his efforts to subdue his opponent by Grappling with him.

A Grapple to the head, neck or torso indicates a hug or choke. A torso Location result will cover both of the Locations level of the body map. For example, a Location to point 4 will cover both 4 and 5. The attack will be against the less effective armor covering the Locations attacked. This kind of Grapple is a constriction attack and armor defends according to the rules on page 17. Any damage done is subdual. The Grappler is assumed to keep his hold on the target unless it is broken or he voluntarily relinquishes it in order to seek a new grip or perform some other Action. As long as the Grapple is maintained, the Grappler may roll his Effect Die at the end of each Action.

A character who has an arm Grappled may not use that arm to perform an Action. That is he may not strike the Grappler with it or use a Skill or weapon requiring two hands. A character whose head, neck or torso is subject to a Grapple may not move.

When a character is considered Grappled he has several options:

- He may execute an Action in an attempt to break the hold of the Grappler. On the last phase of the Action, the character must make a Strength Ability Saving Throw in order to break the Grappler's hold. When his is done the Grappler must make a Strength Ability Saving Throw himself to maintain the hold. If the Grappler fails the Strength Saving Throw, he must make a Speed Ability Saving Throw to avoid falling down. If the Grappler releases his hold before the victim's resolution phase arrives, the victim may abort the attempt to break the hold, as it is unnecessary, and he may initiate an Action on the phase that the Grappler releases the hold.
- He may make an attempt to break the hold using Brawling Combat Skill at full BCS. This will only break the hold. It will not cause damage.
- He may make an attack to cause normal damage using Brawling Combat Skill at -5 to the BCS.
- He may attack the Grappler using another Combat Skill. The BCS receives a penalty of 50% or -5, whichever is greater, plus any situational modifiers. A character attempting to use a Missile Combat Skill also receives this modification to the Deftness Ability Saving Throw required to fire while in Engaged status.

When one character has a hold on another, either may opt to fall down at the start of any Action. This will automatically bring the other character down as well. Each character must have 1D6 rolled for him. The higher roll indicates that the corresponding character has landed on top. In the case of a tie, the character who initiated the fall will be on top. The character on top adds the difference in the Mass of the two characters to the number needed for his Saving Throw (See Falls in Detailed Action Time, below) while the character on the bottom will subtract the difference from the number needed.

FALLS IN DETAILED ACTION TIME

Whenever a character alters position from more or less vertical to horizontal without taking an Action to do so, a Health Saving Throw must be made. If the die result falls in the character's Critical Saving Throw range there will be no effect. If it falls in the character's Ability Saving Throw range, the character will be Dazed for one Combat Turn. A Critical failure, a die roll of 20, indicates that the character has lost consciousness. He will remain unconscious until the controlling player rolls a successful Health Ability Saving Throw for the character. This may be attempted on the bookkeeping phase of each Combat Turn, beginning on the turn after the one on which the character lost consciousness. Upon waking up, the character will be Dazed for one Combat Turn.

Whenever a character falls more than 2 meters, he will be subject to potentially more serious effects. For each 2 meters of fall the character will receive 1D10 of subdual damage. The number of meters fallen is chance in 20 of a Critical Effect occurring. When rolling on the Critical Hit Effects Table, one half of the distance fallen in meters, rounded down, is added to the 1D100. If the Critical Effect is Location dependant 1D100 should be rolled and the Hit Location Table consulted. At his discretion, the Gamesmaster may add to or subtract from the die roll depending on whether the character is falling head or feet first.

EFFECTS OF WATER ON MOVEMENT AND COMBAT

There are three general situations where water will have effects on movement and combat. These occur when the character is ON the water in some form of boat, when the character is actually IN the water, and when the character is UNDER the water.

ON THE WATER

A character on the water will be on some form of "platform" which can range from a raft to a large ocean going ship. Whether the roll of the waves has any effect will depend on the roughness of the water and the size of the "platform." As this is highly variable, it is left to the Gamesmaster to decide if the situation will call for the following rules to be applied.

When the "platform" is affected by the water on which it rides, characters must make a Seamanship Skill roll on each Combat Turn if the effect on the "platform" is significant. With less significant effects, a longer time period may be allowed between rolls. A character may substitute a Natural Talent roll if he has no score in Seamanship Skill or his Talent score exceeds his Seamanship BCS. Once the roll is successfully made, the character will suffer no ill effects for that time period.

Failure to make the roll will cause the character's effective Deftness and Speed scores to be dropped by 25%. Critical failure will drop them by 50%. In both cases, all footing will be considered Treacherous Ground.

Any character without Seamanship Skill will be subject to seasickness when the "platform" is affected by water. A Health Saving Throw must be made. If the die roll is in the Critical Saving Throw range, the character will feel no effects. If it is in the Ability Saving Throw range, he will have his effective Wit, Will, Deftness and Speed Attributes reduced by 25%. All of his Basic Chances of Success will be reduced by 2. If the die roll indicates failure, those Attributes listed above will be reduced by 50% and all BCSs will receive a -4 modification. A critical failure will indicate that the character is overcome by sickness for the duration of the period in which the "platform" is affected.

Whenever the "platform" is affected and the character wishes to exercise any Skill requiring physical exertion, the character's Basic Chance of Success in that Skill should be averaged with his BCS in Seamanship Skill to get a base BCS. The averaged BCS is not allowed to exceed the character's base BCS in the Skill he is attempting to utilize. If the character's Natural Talent score exceeds his Seamanship BCS he may use the Talent score to average with the Skill BCS to give the base BCS.

IN THE WATER

Movement in water will be affected by the relative depth of the water. A check of the table below will give the depth groupings for water and the effect on the Base Movement Allowance.

Depth	BMA	Notes
To ankles	1	Treacherous Ground
To knees	0.5	Treacherous Ground
To waist	0.25	Treacherous Ground
To chest	0.1	Treacherous Ground or character may swim
Over head		Character must swim

Swimming must be performed for an Action. A character may make one 60 degree change of facing during each Action. A character without Swimming Skill will have a Base Movement Allowance of 0.1 but must still roll 1D20 for each Action spent swimming. A result of 20 indicates that the character has "gone under." A character with Swimming Skill will have a Base Movement Allowance of 0.25. If, when he rolls 1D20 during the Action spent swimming, the result is within his Basic Chance of Success, his Base Movement Allowance will be 0.5. A die roll of 20 will call for the character to roll 1D20 again. If the roll exceeds the character's Basic Chance of Success in Swimming Skill or is 20 again, the character has "gone under."

Any attacks made using a weapon in a strike attack form will reduce the character's effective Strength by 25% for purposes of determining the Effect Die.

GOING UNDER

Whenever a character has "gone under," he must make a Health Ability Saving Throw or take 2D6 points of subdual damage from swallowing water. A character who exceeds his Damage Resistance Total in this fashion will become unconscious. If a character's die result is 20, he will immediately become unconscious. Once unconscious, the character will receive 2D6 additional points of damage each Combat Turn. When this additional damage exceeds the value of the character's Damage Resistance Total, the character has drowned.

FLOATING

The time period for checks to see if a character has remained afloat will vary due to water conditions. This is left for the Gamesmaster to adjudicate. To prevent "going under," the character must make a Swimming Skill BCS or a Critical Saving Throw based on the average of the character's effective Strength and effective Health. The character may use whichever value will give him the best chance. A full life jacket will add 12 to the score needed, a life vest or ring will add 10 and other objects such as inflated bladders, drums or wreckage will add 5.

UNDER THE WATER

Movement under the water is the same as for movement in the water. Naturally, if the character has some sort of air supply, it will not matter if he "goes under." This does not refer to holding one's breath. A character may hold his breath for a number of Combat Turns equal to:

6 x Health Group + Effect Die for Will Group The die roll for the Will Group should be made by the Gamesmaster and not revealed to the player. A character who is active while holding his breath will use up his stored oxygen at the rate of 2 Combat Turns for each Combat turn that he is active.

Jan is moving through a submerged tunnel system. She has a Health Group of 3 and a Will Group of 2. This means she can hold her breath for a minimum of 19 Combat Turns while inactive and a minimum of 9 while active. Secretly the Gamesmaster rolls 1D3 for her when she submerges. The result is 2. He now knows her maximum time is 20 Combat Turns.

Jan swims through a tunnel for 8 Combat Turns. This puts her at the end of the tunnel. A check for discovery of Hidden Things expends 1 Turn at inactive rate. The roll is successful and reveals a guard pacing the shore. Jan has now been holding her breath for an effective time of 17 Combat Turns. The player decides that Jan will stay under hoping that the guard will leave before she runs out of breath. By doing this she risks unconsciousness and possible drowning. Two more Combat Turns pass before the guard leaves. On the next Turn Jan surfaces, lungs aching and panting for breath.

Under water a character's effective Strength when using a thrusting weapon will be reduced 25%. If he is using a weapon with a strike attack form his effective Strength will be reduced 50%. Hand held weapons will have modifications to the Basic Chance of Success dependent on the attack form and the size of the weapon. These are listed in the table below. The modifications for thrust attacks replace the normal thrust BCS modifications.

Weapon Length	Strike BCS mod.	Thrust BCS mod.
short	-1	+2
average	-2	+1
long	-4	+0
extra long	-8	-1

OTHER NOTES ON WATER

Visibility in the water varies tremendous according to the clarity of the water, motion conditions and the amount of light available. The Gamesmaster should decide on what the visibility will be when the characters enter the water. It will rarely be above thirty meters and will frequently be less than 4. A character without a face mask or goggles would have about one half the vision range of a character who is equipped with such devices.

Sound travels extremely well in water at a speed of 1.5 kilometers per second. Gamesmaster should take this into account when handling adventures under water.

For game purposes, objects with a negative bouyancy will sink at a rate of 3 meters per Combat Turn. A character with neutral bouyancy (properly weighted for under water work) can move freely in either the vertical or horizontal plane. A character with positive bouyancy (unencumbered) moves horizontally at normal rates and will rise 2 meters per Combat Turn.

Against missile weapons, water will act as a barrier. Each meter of water will add one range step to a muscle powered missile weapon. The air-water interface and the first meter of water will reduce a bullet's BDG by 10. Each successive meter of water will reduce the BDG further by 5.

COMBAT ON A MOVING VEHICLE

The effect on attempts to use a Combat Skill while on board a moving vehicle is straight forward. The character receives a negative modifier to his Basic Chance of Success equal to the number of meters round up, that the vehicle moves in the phase of resolution.

THE CHARACTER AND HIS MOUNT

Being mounted will alter some of the ways a character may act and interact during Detailed Action Time. As long as a character is in control of his mount, his Base Action Phase will determine when the mount will move unless the mount's Base Action Phase is lower. In that case, movement will begin on the mount's Base Action Phase although the character on the animal may initiate an Action on his own Base Action Phase.

If the mount is out of control it will act as if it had no rider except for the effects of the rider's weight. The mount is then in the control of the Gamesmaster and he will move it on the DAT Display.

A rider is assumed to be in control until a situation arises to test his control. This may arise from such things are gunfire, the sudden appearance of something, injury to the mount or anything else the Gamesmaster decrees. If the rider makes his Beast Riding BCS roll he will retain control for that Combat Turn. If he fails the roll, the mount will be treated as uncontrolled beginning on the next Action Phase. The rider must spend an Action to regain control. A successful Beast Riding BCS roll at the end of any Action in which the character is attempting to regain control will return the mount to a controlled state beginning on the next Action Phase. The rider must now deal with the animal at its current speed and direction. The Gamesmaster may apply modifiers to the Basic Chances of Success based on his evaluation of the situation and the reaction of the mount.

A rider initiating an Attack Action while moving will resolve the attack when he passes his Target. He is still constrained to wait the requisite number of Action Phases before

initiating another Action. Whenever a character attempts to use a Combat Skill while mounted, he must average his score in the Combat Skill with his

score in Beast Riding Skill. This will allow him to determine his modified BCS for the Attack according to the rules presented on page 1. This modified BCS is still subject to Restriction, Distraction, Situational Modifiers and the opponent's defense.

While mounted a rider's Combat Dodge Ability is altered. He will have the Combat Dodge Ability value of the mount plus one-half of his own normal value rounded down. His Weapon Defense Ability will be based on his averaged score.

A rider/mount combination moving at a Base Movement Allowance greater than 1 will not be halted by an enemy's Active Zone. Only 1 free attack per opponent is allowed in 1 Action Phase even if the path taken by the mount goes through more than one of the hexes in the opponent's Zone of Influence.

HORSE AND RIDER ON THE DAT DISPLAY

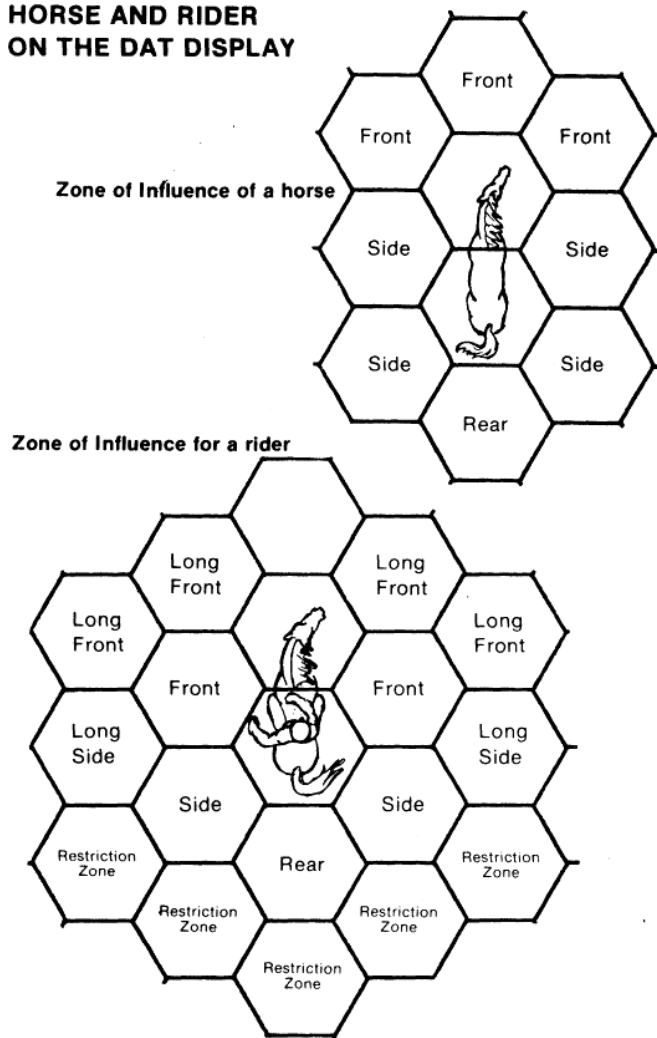

THE HORSE

The most common mount for a man is the horse. The statistics for an average horse are given here:

STR	DFT	SPD	HLH	BAP	MNA	PCA	ODA	DRT
30	14	24	24	12	2	6	2	60
		SF	ENC	CAP	MASS	AV		
		12	12		32	3		
Attack modes:		WDM	Length	BCS	Notes			
Teeth	1.5L	S	7	minus 1 STR Group				
Hoof, unshod	1.5C	A	10	2 attacks when used and a WDA equal to 3				
Hoof, shod		1.7C	A					

A horse has four gaits and each gait has its own Base Movement Allowance. The horse may change a gait to the next slower or faster one at the start of any Action. It must proceed at that speed until the next Action. At any gait with a Base Movement Allowance of greater than 1 only one facing change of 60 degrees per Action is allowed. At these gaits, the horse must move its Base Movement Allowance on each Action Phase. A Speed Ability Saving Throw by an uncontrolled horse will allow it to change to 2 gait classes slower if necessary. A Critical failure will result in the horse falling.

When the horse is controlled, the rider's Beast Riding Skill BCS must first be made. A die roll of 1 for the Horse's Saving Throw or the rider's BCS will allow the gait to be reduced a step further.

Gaits	BMA	Eff. Mass Mod.	Notes
Walk	1	x .25	May start and stop on any phase
Trot	2	x .5	2 in 10 chance of slipping per Action on Treacherous ground
Canter	4	x 1	4 in 10 chance as above Gallop 6 x 1.5 6 in 10 chance as above

A horse's effective Combat Dodge Ability for purposes of incoming missile fire is his BMA times his normal CDA. A horse must be moving at a Walk gait before initiating an Attack Action. Fire directed at the rider suffers the same penalty.

HORSE AND RIDER IN DAT DISPLAY

A horse (for that matter, any animal with a body length between 1 and 2 meters) will occupy two hexes on the DAT Display. When moving forward the front half of the horse will occupy the new hex and the back half will occupy the hex vacated by the front half. The Zone of Influence for a horse is shown in the accompanying illustration.

For purposes of portrayal on the DAT Display, a rider is considered to be in the back hex of his mount. The modifications to his Zone of Influence are shown in the accompanying illustration.

MOUNTED MOVEMENT THROUGH AN OCCUPIED HEX

A rider/mount combination moving through an occupied hex requires a check for Bash to be made. The mount will be reduced to the next lower gait for the rest of its Action. If the Bash goes against it, it will be reduced 1 gait category per 2 meters of Stopping effect. It need not worry about being knocked over until its gait has been reduced to a Walk.

A footman receiving a Bash from a rider/mount combination may be trampled. The Effect Number of the Bash is the chance in 20 that the footman will receive damage as if he had received attacks from two hooves. For this type of attack use the mount's effective Mass as if it were the Strength used to determine the Effect Die.

JUMPING ON HORSEBACK

If the rider makes his Beast Riding BCS, he can cause his mount to jump over an obstacle. The horse must be moving at a gait faster than a Walk. The total distance of the jump (vertical, both up and down, and horizontal) is the Effect Die roll in meters for an effective Strength equal to the horse's Strength minus the Encumbrance Total it is carrying.

For each meter of height that an obstacle has, the horizontal distance required to make the jump is two meters greater than the width of the obstacle. The total additional length is split evenly on either side of the obstacle. Thus an obstacle that is two meters high and two long will require a horizontal jump of six meters and a vertical jump of two meters for a total jump of eight meters. Thus the horse will leave the group two meters in front of the obstacle and land two meters beyond it.

The failed BCS to get the horse to jump will result in the horse independently attempting to decelerate as much as possible to avoid hitting the obstacle. If the horse can slow to a Walk, it will stop on the next Action Phase and the rider must make a Beast Riding BCS to retain his seat. A Critical Miss on the rider's attempt to get the horse to jump will result in the horse crashing into the obstacle. Solid obstacles will cause a number of D10s of B type damage to the horse equal to its BMA when the jump was attempted. The rider will be thrown from the horse and is subject to damage as indicated below.

UNSEATING A RIDER

A rider may be unseated in a number of ways. Once unseated he is subject to damage due to falling. See page 32. The BMA of the horse at the time the rider is unseated is considered as the distance of the fall.

Any Critical Miss on an attempt to control a horse will result in the rider being unseated.

A successful Bash against the rider himself will require a Beast Riding BCS roll where failure will indicate that he has been unhorsed.

A successful Grapple to the legs of a rider will require a check as if the rider had been Bashed. Such Grappling attempts against mounted men are Critical Saving Throws instead of Ability Saving Throws and receive a negative modification equal to the mount's BMA at the time.

"Anchoring" a rider in any way will result in a check for unhorsing as explained below. A rider can be "anchored" by roping him, catching a part of his body, "clotheslining" him or any other method the Gamesmaster declares will have an equivalent effect. Once a rider has been "anchored," the effect will not be checked until the "anchoring" method has been made taut, for example, a rope stretched to its limit. If the rider has time he may attempt to remove the "anchor" sever it or direct his horse in such a way that the "anchor" will not become taut.

In order to see if the unhorsing occurs, each of the contestants will roll the Effect Die for its effective Strength Group. If the rider's roll is higher he will keep his seat. This means that the "anchor" has given way (a Grappling hold or tree limb) or broken (a rope). If the opponent's roll is higher, the rider is unhorsed and subject to the rules for being unseated. If a rider is "anchored" to a solid object (rather than having another character providing the base for the "anchor"), the Gamesmaster must assign a Strength Group for the object. This Strength Group will be the base from which the Effect Die will be determined rather than that of the character who attached the rider to the "anchor." Modifications to the basic strength Groups are given below.

When a rider has been attached to an object, the die rolls will not be made until the mount has travelled sufficient distance to stretch the attaching method taut. If the rider has time he may attempt to remove the attaching method, sever it or direct his horse in such a way that the distance will not become sufficient for the attaching method to become taut.

Situation	Modification
character braced and ready	+1 Group to the character
rider without saddle at Walk	-1 Group to rider
rider without saddle at Trot	-2 Groups to rider
rider without saddle at Canter	-3 Groups to rider
rider without saddle at Gallop	-4 Groups to rider
horse at Canter, rider saddled	+1 Group to rider
horse at Gallop, rider saddled	+2 Groups to rider
rider in high cantled saddle	+1 Group to rider

DAMAGE, HEALTH AND HEALING

As noted in the section on Detailed Action Time, a character can be dealt damage points of lethal, subdual or critical nature. The number of points taken of the first two kinds is compared to the character's Damage Resistance Total to gauge how injured the character is in relation to his normal healthy state. When the total of this representation of injury exceed certain levels the character will register this by a decrease in efficiency.

Lethal damage represents serious injuries which take time for the body to heal. Subdual damage represents less serious injuries that have immediate effects but are compensated for by the body in relatively short order. Critical damage represents very serious damage that prevents the character from utilizing the part of the body that receives such damage. Each type of damage heals differently in the game.

When a character takes damage in the game, the Gamesmaster will specify how much damage is taken and what type of damage it is. The player should enter the amount in the corresponding section of the Character Record Sheet. If the character has already taken some damage, the new damage should be added to the amount already taken.

When the total amount of lethal and subdual damage taken by a character exceeds one half of his Damage Resistance Total, he is considered Wounded. His effective Dexterity and Speed will be reduced by 25% and all applications of Skills will have a modification of -2 to the Basic Chance of Success. When the total of lethal and subdual damage exceeds three quarters of his Damage Resistance Total, the character will be considered Seriously Wounded. His Dexterity and Speed will be reduced by 50% and all BCS will have a modification of -4. It should be remembered that the effects of being Seriously Wounded are not cumulative with the effects of being Wounded. They replace those effects. When the total of damage taken exceeds the character's Damage Resistance Total, he is out of the fight.

If the attack which raised the character's current damage total above the Damage Resistance Total was subdual damage, the character is unconscious. If the attack continues to do subdual damage to the character, he will die when the additional damage exceeds twice his Damage Resistance Total. Such damage can come from continual beating by an attacker or prolonged exposure to electrical current or other sources as decided by the Gamesmaster. If it was lethal damage and the Damage Resistance Total was exceeded by greater than the character's Healing Rate, the character is dead. If the difference between the character's current damage total and his Damage Resistance Total is less than or equal to his Healing Rate, the character is unconscious and comatose.

Critical damage to a location will prevent a character from using that part of his body. Critical damage to the head, neck or body will render the character comatose. When the critical damage is healed the character will regain the use of that body part, or become conscious as appropriate.

HEALING DAMAGE

Subdual damage heals fairly quickly. A character may subtract a number of points equal to his Healing Rate from the total of subdual damage points taken for each ten minutes of game time spent in complete rest. If the character is active the recovery period will be 1 hour instead of 10 minutes. If the character was beyond his Damage Resistance Total when he started healing, he will become conscious when the current damage total is less than his Damage Resistance Total.

The period of healing for lethal damage is one day. For convenience in playing the game, all healing of lethal and critical damage is done at dawn. A character will subtract the points healed from the total of lethal or critical damage taken. The base number of points that a character will heal in a day is equal to his Healing Rate. This number may be increased or decreased according to the character's activities, the care the character receives and the surroundings in which the character finds himself.

The period and modifications for healing critical damage are the same as for lethal damage. However, if a character is suffering from critical and lethal damage, his healing rate will be adjusted by all the appropriate factors. The adjusted Healing Rate will be split in half. One half will be subtracted from the total of lethal damage and one half will be subtracted from the total of critical damage. Odd points are lost.

Broken bones and severed stumps will take time to heal. This time is independent of any other healing that takes place. A character trying to be active during this healing time will be greatly hampered. The exact problems he will suffer is left to the Gamesmaster. The time required to heal such an injury is 100 days minus 1Day for each point of Health score the character has at the start of the healing process. An Advanced Medical Skill BCS roll is required to set broken bones correctly. Healing time will be dated from the day the bones are set. If they must be reset the healing time will start all over from the beginning. Stumps resulting from a Sever result must have an Advanced Medical Skill BCS roll applied to them if they are to later accept prosthetic devices.

MODIFICATIONS TO HEALING RATE:

Patient is in the field, complete rest	0
Patient is in the field, active up to one half day	-1
Patient is in the field, active for full day	-2
Patient engages in active combat that day	-1
Patient is in restful surroundings	+1
Patient receives good physical care (food, rest, etc.)	+1
Patient receives medical care (character attending makes BCS roll)	+1
Patient receives good medical care (hospital)	+1

Martin the Traveller has a DRT of 24 and a Healing Rate of 3. He has been injured in a fight. He has taken 12 points of lethal damage, 4 points of subdual damage and 4 points of critical damage to his left arm. He decides to rest after the fight. After 20 minutes the subdual damage will be "healed." Looking around he decides that the climate would be healthier elsewhere. He heads for the nearest town. He travels for a full day and is jumped by a brigand at sunset. He kills the felon and miraculously escapes further injury. Having traveled at full movement he gets -2 to his Healing Rate. The -1 for having engaged in combat reduces his Rate to 0. He will not heal that day.

The Traveller decides to spend a day resting to get some strength back. He avoids all encounters that day. He therefore gets his full healing rate. He divides this between the lethal and critical damage with the extra point being lost. He now has 1 1 points of lethal and 3 points of critical damage.

After a half days travel, Martin finds himself at a small farmhouse. He persuades the family to let him stay the night. Later that afternoon, a wandering physician arrives. The doctor makes his First Aid Skill BCS roll so Martin adds +1 to his Healing Rate. The half day's travel costs him 1 but the restful surroundings of the cottage cancel that with +1. The net gain of 1 allows him to reduce the total of lethal damage to 9 and the critical damage to 1.

IMMEDIATE FIRST AID

Immediately after a combat, characters may receive first aid. Each of the measures listed below will allow a character to immediately subtract one point of lethal damage from the current total. If not applied in the space of time immediately after the combat, no effect will be gained. These measures include:

- Character makes BCS roll with First Aid Skill (die roll equals 1:2 points)
- Patient is bandaged (requires bandage materials)

- Patient is given 1 unit of medical supplies (non-cumulative)

RESTORATION OF LOST ATTRIBUTE POINTS

If the character has lost Attribute points due to some form of attack, he may regain them at a rate equal to one half his Healing Rate, rounded down, per week. His Healing Rate for this purpose is subject to similar modifications to those received when healing lethal or critical damage. In this case, though, the period is a week instead of a day for each modification and the appropriate medical care is Therapy Skill, not First Aid Skill. All modifications are made to the character's Healing Rate before it is halved. By this method a character may not regain Attribute points lost due to aging.

RESTORING A CHARACTER TO CONSCIOUSNESS

If a character is unconscious due to System Shock, a Critical Effect result of having his Damage Resistance Total exceeded by a subdual attack, he may be restored to consciousness by another character who makes his BCS roll for Advanced Medical Skill. If the character is unconscious due to being in a comatose state, the reason for the coma must be eliminated first. If coma was caused by critical damage to the head, neck or body, the critical damage must first be healed. If it is due to the character's Damage Resistance Total being exceeded by lethal damage, the character's current damage total must be lowered to within his Damage Resistance Total.

INFECTION

A character may be subject to infection if Lethal or Critical damage has been caused to him by the bite of a predator or scavenger, an attack with a dirty or rusty weapon or, if the character does not keep himself decently clean (for example, sleeps in his armor for days on end), any weapon that breaks the skin.

Once the character is exposed to an opportunity for infection to set in, the Gamesmaster will make a secret Health Ability Saving Throw for the character. This throw should be made at the next time that healing would be calculated. If the throw is failed, the wound has become infected, The character may not heal as long as he is subject to the infection.

Infection may be avoided by the application of a unit of medical supplies when first aid is supplied. This unit is over and above any applied for first aid healing. Also, any character applying a BCS roll to the infected character while utilizing Pathology Skill will eliminate the infection. The attempt to apply Pathology Skill may only be made once per patient for each infection possibility.

Once the character is infected, recognizable symptoms will appear at the next time healing would be calculated. On each successive day, the character may attempt Health Ability Saving Throws to throw off the infection. The character will heal normally on the day after the infection is thrown off.

OPTION

If, in a character's Health Ability Saving Throws to eliminate an infection, a 20 should be thrown, gangrene will set in. Gangrene negates the characters ability to make Health Saving Throws. Gangrene has an initial Virulence Group of 1 which will increase by 1 Group each day. Each day the Gamesmaster will roll the Effect Die for the current Virulence Group of the Gangrene. When the total of the Effect Die rolls exceeds the character's Damage Resistance Total, the character is dead.

Each day a character with Pathology Skill may attempt to halt the progress of the disease. His Basic Chance of Success will be halved if he does not expend a number of units of medical supplies equal to the current Virulence Group of the Gangrene. In addition the base BCS will receive a negative modification equal to the current Virulence Group of the Gangrene.

Treat the accumulated results of the Effect die rolls of the Gangrene as critical damage for purposes of healing if the disease is thrown off.

DISEASES

Diseases can be broken down into three basic formats: acute, episodic and chronic. In game formula they will be coded (-), (+) and (0) respectively.

Each time an acute disease has an effect, whether its first effect of at the end of a Cycle, it will subtract the result of its Effect Die from its target Attribute, The character must then function at the reduced value of the Attribute. When the disease reduces the target Attribute to zero or below, the Crisis stage is reached.

When dealing with an episodic disease, a count of the cumulative result of the Effect Die rolls is kept. When the total exceeds the Critical Saving Throw range in the target Attribute, the Attribute will be reduced by 25% till the disease achieves its next stage. When the total exceeds the Ability Saving Throw range, the target Attribute will be reduced to 50% for the

duration of the disease. At the end of each Cycle of the disease, the character is allowed to make an Ability Saving Throw with the target Attribute to avoid specific episode effects. A specific episode automatically occurs when the disease first takes effect. When the total of the Effect Die rolls exceeds the score in the target Attribute, the Crisis state occurs.

A chronic disease will have its effect at the end of the Incubation Period. This effect will remain until the character throws off the disease or the time limit on the duration of the disease runs out. If a target Attribute is specified, it will be decreased by the Effect Die roll for the duration of the disease. The Attribute will return to normal at the end of the disease.

If a disease has more than one main target, each will be treated independently. The Crisis stage will occur when the first Attribute satisfies the conditions for its occurrence.

Diseases may also have specific symptoms which will have an effect on the character. If a disease has such symptoms they will be listed after the formulaic expression of the disease. Such symptoms last for the duration of the disease but may be temporarily alleviated by the application of symptomatic drugs.

Each strain of a disease will be rated for its Virulence Group. This is a measure of how strong the disease is as well as how dangerous it is. At the end of each Cycle of an acute or episodic disease, the Gamesmaster will roll the Effect Die for the Virulence Group of the disease. This will be the progress made by the disease for that cycle.

A disease has an Incubation Period, This is the time between exposure to the source of the disease and the first appearance of symptoms. This will vary by strain. The time period of the Incubation Period will be reduced by the Virulence Group. This reduction will be in whatever units of time in which the Incubation Period is expressed. At the end of the Incubation Period the disease will make its first attack.

The Vector of a disease is a description of the method by which the character can catch the disease. If the character has protection from the Vector, he can not contract the disease. The Vectors and their descriptions follow:

Aerosol — The infection is airborne. Any character within a number of meters equal to the Virulence Group who breaths the air is subject to Infection.

Subcutaneous — The infection must be gotten under the character's skin by such means as an animal bite, wound, injection, etc.

Gastric — The source of infection must be taken internally through such things as contaminated food or drink.

Dermal — Simple skin contact is required. A garment that protects a character from the initial source of infection may later cause the character to be subject to infection if it carries contamination from the original contact.

Within these rules a disease will be described in the following method:

Vector - Format - Target - Incubation Period -Virulence Group - Cycle time

This will be followed by any special notes including any symptoms or specifics regarding the "episode" of an episodic disease.

Abbreviations in use will include the standard abbreviations for Attributes and time. Vector will be abbreviated as the first letter of its name. Thus, an acute disease with an Aerosol Vector that attacks the Wit of a character and has an Incubation Period of 12 hours, a Cycle of 3 hours and a Virulence Group of 4 would be abbreviated as:

A - (-) - WT - 12hr. - 4 - 3hr.

If the disease were episodic and the episode was a fit of paranoid delusion it would be:

A - (+) - WT - 12 hr. - 4 - 3 hr. - paranoid delusion episode

If the disease were chronic it would be:

A - (0) - WT - 12hr. - 4 - 0

Since more than one disease may have the same game formula, each disease should be specified by name. This allows one to distinguish between an antibiotic tailored for a specific disease and an antibiotic that only corresponds on all principal factors. Specific diseases will be presented in Book 3.

DISEASE SYMPTOMS

This section presents typical disease symptoms and the effects on the character with the disease. Not all diseases will have symptoms as severe as these. Many diseases will have these type of symptoms but their effects will not be great enough to warrant an effect on the character.

Attribute Dysfunction — The specified Attribute has its effective Group lowered by the total advance divided by 10, rounded down.

Dizziness — When the disease's advance is greater than the character's Health CST, treat all of the character's movement as if he were on Treacherous Ground. If the terrain is truly Treacherous Ground, double his chances of slipping. When the advance exceeds his Health AST, subtract the Virulence Group of the disease from the number needed to make any Saving Throws involving the character's sense of balance such as those required for keeping one's feet, catching things, dodging, etc.

Dystopia — When the advance is greater than the character's Health CST, the effective Light level for that character is reduced by one step. That is Good light becomes Dim, Dim becomes Poor, etc. When the advance exceeds his Health AST, the reduction is two steps.

Fainting — Faints are treated as System Shock. A character who fails a Physical Attribute Saving Throw is subject to a check for Fainting. He must make a Health Ability Saving Throw to avoid Fainting. The number needed for the Saving Throw is reduced by the Virulence Group of the disease. Continued exertion may also cause the character to check for Fainting. The character's Health Group is the number of Combat Turns he may engage in strenuous activities such as combat, running, climbing, etc., before he must make a Health AST as above. If he does not Faint when he checks for it he may continue to exert himself for the same time period before he must check again.

Lesions — The day's advance of the disease is the chance in 10 of lesions developing on a random Location. Any damage taken on that Location will expose the character to Infection.

Nausea — Exertion as described in fainting or a successful attack on Locations 6 through 12 will require a Health AST to avoid a fit. The character experiencing a fit of vomiting will be unable to perform any Action for a full Combat Turn. He will remain incapacitated until he makes a Health AST. Attempts to throw off the fit may be made on the bookkeeping phase of the Combat Turn.

Pain — The disease's advance for that day acts as a negative modifier to all BCS rolls attempted by the character. One half the value of the advance is subtracted from the number needed for any Saving Throws.

Paralysis — The specified extremity will take critical damage equal to the day's advance of the disease.

Puerperal — The character's blood is slow to clot, though not so bad as a case of hemophilia would make it. But he will tend to bleed from open wounds and to suffer severe bruising from non-cutting blows. When Lethal damage is taken, after the combat in which it was taken is over, and any medical attention is given to the character that falls in the classification of immediate first aid, total up the character's current Lethal Damage total and calculate a Group from the total. Roll the effect die for this Group and add that to the character's total damage tally as Lethal damage. In the event that this drives him below 0, he will become comatose. Under no circumstances will the additional damage kill him. If it reduces his DRT to the death point, it stops there, and no extra damage for puerpera is assessed. The character is comatose from blood loss.

When Subdual Damage from any blow is taken to the limbs, the total Subdual Damage done is the percent chance that the limb will suffer a Disable result, as described in Critical Effects. The character will lose the use of the limb until a Health AST is made, rolling hourly. Blows to the body or head will not have any appreciable effect on the puerperal symptom, in terms of Subdual damage's effects.

Rheumatoid Condition — The effects of this symptom vary by the location affected. If it affects the legs, the character's Base Movement Allowance will be halved when the disease's advance is greater than his Health CST. It will be reduced to one quarter of its normal value when advance exceeds Health AST. If it affects arms, torso or head, when the advance exceeds the Health OST all attacks that the character makes out of his Side hexes are treated as attacks out Rear hexes and the. Front hexes are treated as Side hexes. When the advance passes his Health AST, attacks out any of his hexes are treated as Rear hexes. If it affects the hands, the character's Dexterity Group will be reduced by the total advance divided by 10, round down, for determining the effects of all operations requiring manual dexterity such as lockpicking, crafts, etc.

Tinnitus — The day's advance of the disease is the number of distractions the character receives due to ringing in his ears. Any Saving Throws utilizing his sense of hearing will also receive this negative modification.

Ulceration — The day's advance of the disease is the chance in 10 that the character will develop ulcers on a Location. This should be determined

by making a Hit Location roll. If the character receives any damage to an ulcerated Location he must check for System Shock. The character is also exposed to Infection, see page 37.

Weakness — When the disease's advance is greater than the character's Health CST his effective Strength, Dexterity and Speed are reduced 25% and he receives 1 to all physical BCS rolls. When the advance is greater than his Health AST, the penalty to those Attributes is 500/o and -2 on physical BCS rolls.

DEALING WITH DISEASE

When a character is first exposed to a disease, a Health Ability Saving Throw must be made. The number required for success will be modified downwards by the Virulence Group of the disease. If the throw is successful, the character has avoided contracting the disease. No further checks are necessary while he is in the vicinity of the source of infection. If the character should leave the area and return on another day he would be subject to possible infection again.

Once the disease has been contracted, the victim has an opportunity during the incubation period to throw off the disease before any ill effects occur. This attempt requires that a character make a successful Basic Chance of Success roll using Pathology Skill. This Basic Chance of Success receives a negative modification, to the number needed, equal to the Virulence Group of the disease. Once the Pathology Skill BCS is successful the victim is allowed to make a Health Ability Saving Throw to rid himself of the disease.

Alternatively, application of a broadband antibiotic or a specific antibiotic for the disease will allow the victim to make the second Health Ability Saving Throw. The exact drug used will add its efficiency against the disease to the number required for a successful Saving Throw. If a drug is applied by a character who makes a successful BCS roll using Pathology Skill, the strength of the drug will be added to the number required for the patient's Saving Throw.

Only one attempt to throw off the disease may be made during the Incubation Period.

At the end of the Incubation Period the first effects of the disease will appear. If the disease has no Cycle, these effects will remain in force until the character makes a Health Saving Throw against the disease or the disease runs its course. A Saving Throw against the disease may be made at the beginning of each day. Once the disease is no longer active in the character's system, the effects of the disease will disappear or he will be able to start healing the effects. The exact result will be dependant on the exact disease.

If the disease has a Cycle, the character is allowed to make a Health Saving Throw at the end of the Cycle time before the disease's advance is determined. If the die roll is in the range for a Critical Saving Throw, the disease is thrown off. If the die roll is in the range for an Ability Saving Throw, the disease is being held in check by the character's immunoresponse system and it makes no advance for that Cycle. Once the disease is thrown off, the character may go about the business of recovering from the disease.

When a victim is making his Saving Throw at the beginning of a day or at the end of a Cycle, he will receive modifications to the number needed for a successful Saving Throw as follows:

- If a character makes a Pathology Skill BCS roll, modified as usual by the disease's Virulence Group, a plus 1 is received.
- If a broad-band antibiotic is administered, a plus equal to its strength is received.
- If a specific antibiotic is administered, a plus equal to the specific's efficiency against the disease is received.
- If the character is wounded (greater than 50% of DRT), a minus 1 is received.
- If the character is seriously wounded (greater than 75% of DRT), a minus 2 is received.

These modifications affect both the Critical and Ability Saving Throw Ranges.

CRISIS POINT OF THE DISEASE

When an acute disease has reduced its main target to zero or below, when an episodic disease has a cumulative total of its Effect Die rolls that exceeds the character's score in the disease's main target, or when a disease reaches a specified stage with a chronic disease, the patient has reached the Crisis point of the disease. The character is allowed a last Saving Throw to eliminate the disease. This will be a Health Critical Saving Throw. No modifications are allowed. If the character fails this throw, he has

died of the disease. If the throw is successful, the character may begin the process of recovery.

DOCTORS AND DISEASE

Once a patient is evidencing the symptoms of a disease, a character with Pathology Skill may attempt to diagnose the disease by making a Basic Chance of Success roll. This will allow the player to know the formula, in game terms, for the disease. This is important in choosing a specific antibiotic, if one is to be used.

Other specific uses of Pathology Skill with regard to disease have been dealt with above. In brief, a successful Basic Chance of Success roll will allow a character a Saving Throw during the Incubation Period or modify the number required for a Saving Throw that the character normally makes in the course of the disease.

Valeria, in her career as a wandering adventurer, has been in many places. She has also caught many diseases. Early on she caught a stomach bug fitting the description: G - (0) - STR - 4 hr. -2 - 0-48 hr. The inn she was staying at had bad food that night. With a Health of 15 and a die roll of 1020 of 16, she failed her Ability Saving Throw to avoid catching the disease. After 4 hours the disease made its first attack. The Gamesmaster rolled 1D6 with a result of 5. This was from the Virulence Group of the disease being 2 and having an Effect Die of 1D6. Thus her Strength is reduced by 5 for the duration of the disease which will be 48 hours. After 24 hours, that is 1 Day, she again fails her Health AS T with a die roll of 12. She has no need to roll at the end of the next 24 hour period since the disease will have run its course and will cease. Her Strength may then be healed to its normal level.

Several months later, Valeria was bitten by a dog which was foaming at the mouth. Again she failed her initial Saving Throw to avoid the disease. Fortunately for her, a companion had Pathology Skill with a BCS of 12. The Virulence Group of the disease was 4 which reduced his BCS to 8. A die roll of 4 on 1020 allowed her to make another Saving Throw during the Incubation Period. This time the die roll was a 7. She just barely avoided coming down with the disease. This disease had the formula:

5 - (+) - WL - 3 hr. - 4 - 4hr. - homicidal mania episode.

Let us look into an alternate universe where Valeria's companion did not make his BCS roll. Three hours after infection, the Gamesmaster rolls 2D6 as the Effect Die for the disease since it has a Virulence Group of 4. The result is 3. Valeria has a Will of 23 (CST equals 8; AST equals 11). Symptoms appear which indicate that Valeria has caught a disease, but no specific effects appear because the cumulative total of Effect Die rolls is less than her Will CST. She does however have an episode of homicidal mania. After subduing Valeria, her companion attempts to diagnose the disease by making a Pathology Skill BCS roll. The die result is 7. This indicates success, so the player controlling the companion is given the formula for the disease. He does not have any specific antibiotics to use against the disease. Before the next Cycle of the disease, he attempts another Pathology Skill BCS roll to help Valeria throw off the disease. He also gives her a broad-band antibiotic. The BCS die roll is a 3, so Valeria will add 1 for that and 1 for the broad-band antibiotic to the range of her CST and AST. This means her effective scores for this Cycle are CST equals 7 and AST equals 9 instead of 5 and 7 respectively. The die roll is 8 indicating that the disease has been held in check and will not advance at this point. Valeria fails her Will AST and has another fit but she is restrained and harms no one.

At the next Cycle, the companion fails his BCS roll and has run out of broad-band antibiotic. The die roll of Valeria's Health Saving Throw is again an 8 but this time it indicates failure. The die roll for the disease is 9 bringing the total to 13. Valeria gets to make her Will AST before the effects of the disease's advance take effect. her roll is a 2 meaning that she will not have a fit this time. Because the disease's advance has exceeded her Will AST value, her effective score in the Target Attribute of Will is reduced by 50% to 12 making her new CST equal 4 and AST equal 6. Remember that the disease's advance is compared to the permanent value of the Attribute.

On the third Cycle, Valeria gets a 2 for her Health Saving Throw. She has thrown off the disease. Her Will returns to normal but the damage she took while being subdued by her companions must be healed.

Two years later, while poking her nose where it didn't belong, Valeria picked up another bug, and as usual didn't make her Health AS T to avoid infection. This one was: D - (-) - DFT - 12 hr. - 3 - 12hr. At the end of the Incubation Period, the first Effect Die roll for the disease was 5 on 2D10. Valeria's Deftness score was immediately reduced by 5. Twelve hours later, she again failed her Saving Throw and the Effect Die result was 3. Her Deftness was reduced by 3 more points. This brought her Deftness to zero. She went immediately into Crisis. The die roll for her last attempt to rid herself of the disease before it killed her was a 4. It was well within the

Critical Saving Throw range as required. Valeria survived the disease but would be quite a while recovering the lost points of Deftness.

ANTIBIOTICS AND DISEASE

Various cultures will have remedies, processes, and/or drugs which will aid a person who is fighting a disease. To simplify matters for the game, we will refer to such things as antibiotics. A broad-band antibiotic is designed to fight a disease by fighting its symptoms and bolstering the body's natural defenses. A specific antibiotic is more or less tailored to the disease and fights the disease directly.

A broad-band antibiotic will be rated for its strength. This is the amount it will raise the Saving Throw of the patient receiving it.

A specific antibiotic will also be rated for strength. It will, however raise the number needed for a successful throw on the patient's part by its efficiency. The efficiency of a specific antibiotic is the result of the multiplication of its strength times its correspondance factor. The correspondance factor is determined by comparing the formula for the antibiotic to the formula for the disease. The antibiotic is rated for Format, Target, Vector and each specific secondary characteristic such as the nature of an episode. The correspondance factor is the nature of these that the antibiotic has in common with the disease.

Any antibiotic specified as being tailored to cure a specific disease will, upon being administered to the patient, cure the disease at that point. The character will be at the recovery stage of the disease. A tailored antibiotic will generally also cure any side effects of a disease.

The formula format for an antibiotic follows exactly that of a disease to facilitate comparison.

For this example let us refer back to the previous one and the second disease which has a formula of S - (+) - WL - 3 hr. - 4 - 4 hr. - homicidal mania episode. Consider Valeria's companion who had diagnosed the disease. Suppose he had the following specific antibiotic to give to Valeria instead of the broad-band antibiotic: S - (-) - WL homicidal mania episode. It corresponds to the disease on three points. It would add 3 instead of the 1 added by the broad-band antibiotic. This would have raised Valeria's effective Saving Throw ranges to CST equals 9 and AST equals 11. The die roll of 8 would have meant that she threw off the disease at that point and would not have had the second fit of homicidal mania.

RECOVERY FROM DISEASE

When a character throws off a disease or survives a disease because it has run its course, he will receive 1D10 of subdual damage for each Virulence Group of the disease. This is curable in the normal fashion, see page 36. The character is also able to begin the process of healing any Attribute points lost due to the disease. This process is dealt with on page 37.

If the disease was specified to have had side effects, the character will of course be suffering from them. Whether such side effects can be healed will depend on their nature. The process for healing reversible side effects will be detailed in the description of that disease that causes them.

OPTION IMMUNITY FROM DISEASE

Any character who has once had a specific strain of an acute or episodic disease will be immune to that strain in the future. In game terms, this means that a character who has made his Saving Throw after the first effects of the disease have evidenced themselves will automatically make his Health Ability Saving Throw when exposed to the same strain of the disease.

The bookkeeping of which strains the character has had is the responsibility of the player. When the character is exposed to a disease, the player should inform the Gamesmaster of the strains to which the character is immune. The Gamesmaster will take this information into account but should have the player roll a Saving Throw for the character anyway, since even an immune character has no natural automatic way of recognizing a strain of disease.

POISONS

Poisons function much like diseases since they have characteristics that resemble Vector, Incubation Period, Virulence Group, and Cycle Time. The effects that a poison has will depend on its type and whether it has any side effects. The three general types of poisons are lethal, narcotic and depressant.

The Vector of a poison is the same as that of a disease. That is, it may be Aerosol, Subcutaneous, Gastric or Dermal. This is the method by which the poison is introduced into the character's system.

Once the poison has been introduced to the character's system, there will be a period of time until it first shows its effects. During this time attempts may be made to remove the poison from the character's system. The exact requirements and procedures will depend on the Vector as follows:

Aerosol — Application of an antidote is the only way to halt this type of poison before it takes effect.

Subcutaneous — A successful application of First Aid Skill will remove the poison before it causes harm.

Gastric — The proper aid to apply can be one of two kinds, induced vomiting or dilution. A successful BCS roll utilizing Advanced Medical Skill will determine which is appropriate. In either case, a First Aid Skill BCS will apply the required aid. In the former case, the recipient will be incapacitated until he makes a Health Ability Saving Throw. Attempts may be made on the bookkeeping phase of each Combat Turn. In the latter case, a number of units of the correct substance (water, acid, base, etc.) equal to the strength of the poison is required. If an insufficient number is available, the number used will reduce the strength of the poison by the number administered. Application of the wrong aid will reduce the recipient's required Saving Throw to cancel the effects of the poison from the Ability to the Critical range.

Dermal — The proper aid to apply may be one of two kinds, flushing or treatment. A successful BCS roll utilizing Advanced Medical Skill will determine which is appropriate. In the former case application of one liter of solvent (such as water) per Location covered by the poison for each Strength point that the poison has is required. If insufficient water is available, the water that is applied will reduce the strength of the poison by one point for each unit amount applied. In the latter case, an Advanced Medical Skill BCS and the application of a number of medical supplies equal to the strength of the poison is required. If the BCS is made and an insufficient number of units of medical supplies is applied, the poison's strength will be reduced by the number of units of supplies that are applied. In either case, the application of the wrong kind of aid will have no effect on the action of the poison.

At the end of the Incubation Period, the character must make a Health Ability Saving Throw, assuming the poison has not been counteracted. If the Saving Throw is made, the poison will have no effect. If it is failed, the poison will begin to take effect. The strength of the poison works as the Virulence Group of a disease. It is used as a Group rating to determine an Effect Die. The proper die is rolled by the Gamesmaster and the result is noted.

The main Target of all poisons is the character's Health. When the cumulative total of the Effect Die rolls exceeds the character's Critical Saving Throw range, first stage effects occur. When the cumulative total exceeds the Ability Saving Throw range, second stage effects occur. When the cumulative total exceeds the character's Health score the Crisis stage occurs. The effects at each stage for each kind of poison are dealt with later in this section.

At the end of the Cycle Time for the poison, the character is allowed to make a Health Saving Throw. If the die roll is in the Critical Saving Throw range the strength of the poison will be reduced by one Group and no die roll will be made for the poison that Cycle. If the die roll is in the Ability Saving Throw range, no die roll will be made for the poison on that Cycle. This process will continue until the character has reduced the effective strength of the poison to zero or the poison has had its Crisis stage effects.

Additional doses of a poison will act to restore the strength of the poison to its strongest level. They will not increase it beyond the maximum for its current form and strength. Additional doses do not, however, have to go through the Incubation Period.

EFFECTS OF POISONS

If a specific poison is listed as having side effects or 'episodes' they will occur at the times and have the effects that are detailed in the description of the poison. The general effects of each kind of poison are presented below:

Lethal

First Stage — The Attributes specified as targets of the poison are reduced by 25%, All BCS rolls are -1.

Second Stage — The target Attributes are reduced by 50%, All BCS rolls are -2.

Crisis Stage — The character is allowed one last Health Critical Saving Throw. Failure indicates death. Success leaves the character comatose. After recovering consciousness the character will have the target Attributes reduced by the strength of the poison. This damage may be healed following the rules on page 37.

Narcotic

First Stage — The character's Wit, Dexterity and Speed are reduced by 25%, All BCS rolls are at -2.

Second Stage — The character's Wit, Dexterity and Speed are reduced by 50%, All BCS rolls are at -4.

Crisis Stage — The character is rendered unconscious. This state will naturally last for a number of hours equal to the strength of the poison.

Depressant

First and Second Stage — as with Narcotic.

Crisis Stage — Character retains reduced values of the affected Attributes, All BCS rolls are at half value. This condition will last for a period of hours equal to the strength of the poison.

Any character surviving the Crisis stage of a poison will have symptoms equivalent to the second stage effects of a narcotic poison at the end of the time period of the Crisis stage effects. This will last for a number of hours equal to the strength of the poison or until the character makes a Health Ability Saving Throw. This may be attempted once per hour. The character will then evidence symptoms equivalent to first stage narcotic poisoning for a number of hours equal to the strength of the poison or until a Health Ability Saving Throw is made. At this time the character will return to his normal condition barring any side effects or damage caused by the poison.

TREATMENT OF POISONING

If a character is poisoned, treatment may be applied to counteract or remove the poison as specified in the description on the Vectors of poisons earlier in this section. Once the Gamesmaster has made the first Effect Die roll for the poison, the only treatment allowed is for the symptoms by the use of drugs or some other method that will negate the effects of the poison at that level. The poison will continue to work its insidious way in the character's system. Only by making Saving Throws can the character rid his system of poison unless a specific antidote is available.

Specific antidotes work with poisons exactly as specific antibiotics work with diseases. The points of correspondance are Attributes attacked (all must correspond to count as one factor), Type, Vector and any specific side effects. A tailored antidote will negate the poison after completion of its own Incubation Period. See page 40 for the mechanics of antibiotics. Antidote formulae follow the same format as poison formulae.

ENCODING A POISON

The procedure for encoding the game formula for a poison works much the same as the process for the game formula of a disease. The basic format is:

Vector - Type - Attribute(s) attacked - Incubation Period - Strength - Cycle Time - notes.

The code for the type is the first letter of its name. Thus, a fast acting Dermal nerve poison might have a formula as follows:

D, dilution (water) - L - DFT, SPD - 0 - 3 - 1/2 Combat Turn - 1 Combat Turn - Survivors have 1 Distraction Factor under stress due to nervous twitching.

Specific poisons will be detailed later for the Gamesmaster.

Jaxom is moving through the forest. Suddenly he feels a sharp sting and looks down to see a blowgun dart imbedded in his arm. It is dipped in the following poison: S - L - DFT, SPD - 0 - 3 - 1/2 Combat turn. The Incubation Period is 0 so there is no time to provide treatment for the poison. At the start of this action Jaxom has a Health of 12, a Dexterity of 22 and a Speed of 15. Jaxom's Health Ability Saving Throw attempt yields a die roll result of 7 which is one above the necessary score. The poison will have its first effects on the bookkeeping phase of that Combat Turn. The first Effect Die roll is a 6 which exceeds Jaxom's Health CS T value. At this point his Dexterity and Speed will be reduced by 25% and all his BCS rolls have a -1 modifier. Since the poison has a Cycle Time of 1/2 of a Combat Turn, it has an assumed Base Action Phase of 20 and will do its insidious work on phases 1 1 and 1 until it kills him or is negated.

Jaxom's next Health Saving Throw, done on next Combat Turn is a 3 which will reduce the strength of the poison to 2 and prevent it from having further effects at this time. On phase 6, which is Jaxom's current Base Action Phase since the action of the poison has reduced his Speed to 1, he initiates a Survey and Command Action to discover where his assailant is and to warn his companions. But on phase 4, another dart thuds home. Jaxom's Saving Throw fails again restoring the strength of poison active in his system to 3. On phase 1. Jaxom will make a Health Saving Throw and fail. The poison's Effect Die roll is a 4 which brings the total to 10. This

exceeds the AST range and the poison has its second stage effects. His Deftness drops to 8 and his Speed to 11.

For the next two Combat Turns. Jaxom makes his Health Saving Throws in the AST range. This halts the advance of the poison but does not reduce its effects. On the next roll he fails his Saving Throw and the Effect Die roll for the poison is 4. This brings the total to 14 (which exceeds his Health score) and the Crisis stage begins immediately.

Jaxom makes his Health Critical Saving Throw. He is comatose. When he finally recovers consciousness, he will be under the second stage effects of a narcotic poison for up to 3 hours and then will evidence first stage effects for up to an additional 3 hours. His Deftness and Speed will be reduced by 3 until healed.

CHARACTER IMPROVEMENT

As the game progresses, the player will wish to see his character improve his abilities, his chances of success and, in short, his ability to survive. Since this system contains no artificial "level" increments as a measure of a character's abilities, the character must be improved in other ways. Diligent study, rigorous training and learning through practical experience are all valid ways for the character to improve.

The process of improvement may be rapid or slow depending on the situation surrounding the improvement and the character himself.

IMPROVING SKILLS

A character may improve his score in a Skill in one of two ways. These are Study and Learning-by-doing. In both processes, it is the score in the Skill, not the Basic Chance of Success that is raised by the amount indicated. The Basic Chance of Success will increase when the character's score is raised sufficiently that a new calculation of the BCS yields a higher number. Remember that a character has one point of Basic Chance of Success for every five points of Skill score.

A Skill score may not be increased over the maximum score. Any extra points are lost. When a character reaches a score of 100 (BCS 20) in most Skills, he has learned what there is to know in that Skill. He is assumed to be an effective master of the Skill. A die roll of 20 when making a Basic Chance of Success roll will still indicate failure but in most cases the failure will not have critical effects. When using a Combat Skill which has a maximum score of 200 (though the BCS maximum is still 20) a die roll of 20 will indicate that critical effects occur if the character cannot make a Control Throw (the BCS of the second 100 points). A character with a score of 200 in a Combat Skill will still feel critical effects if the die roll on the Control Throw is a 20.

LEARNING-BY-DOING

When the character has successfully utilized a Skill, he may attempt to Learn-by-doing. It is the responsibility of the Gamesmaster to decide if a Skill use during the game makes the character eligible for the attempt. The general requirement the use of the Skill significantly advances the position of the characters in the game situation. Thus a character who spends his time between adventures rolling his BCS in Lockpicking Skill is ineligible since there is no pressure on him, no significant need for locks to be picked and he is facing no new challenges. The character is effectively conducting Solo Study as detailed later in this section.

A character is allowed to attempt to Learn-by-doing for each eligible Skill used successfully in a Detailed Action Time situation. Multiple successes in one Skill during a given DAT situation will not allow more than one attempt to Learn-by-doing.

To be able to Learn-by-doing the character must have a score greater than zero in the Governing Talent for the Skill. The Governing Talent is the first Talent listed in the calculation for the initial score in the Skill.

In order to successfully Learn-by-doing, the character must roll less than or equal to his score in that Governing Talent on 1D20. If he does so, he may add one to his score in that Skill.

When a character is using two Skills averaged together to gain his Basic Chance of Success, if he succeeds and is allowed to Learn-by-doing, he may choose which of the two he will attempt to Learn-by-doing with. Multiple successes with the averaged BCS will not allow him to attempt to Learn-by-doing with both of the Skills involved.

Jus Dogslayer is proceeding through a occupied building. He picks the lock to the cellar stairs. Check for Learning-by-doing. He then locks the door behind him and proceeds down the stairs. Out of the dark, a figure attacks him. Drawing his sword and knife, Jus tightens using Two Weapon form of HTH Combat Skill. Just as he slays this man, another comes at him. Jus wounds the second man with his knife, just before having it knocked from his

hand. Now Jus fights on using Single Weapon form of HTH Combat Skill. He dispatches his opponent.

At this point, Jus, having used Two Weapon Skill successfully against both opponents, can check for Learning-by-doing for that Skill. Although he fought two opponents, it was during the same Detailed Action Time. He may also check for Learning-by-doing with regard to Single Weapon Skill since he used that Skill successfully against the second man.

Jus now hears more men approaching and opts for the better part of valor. He uses his Stealth Skill to move silently back up the stairs. Check for Learning-by-doing because noise would attract attention to Jus.

Upon reaching the top of the stairs, Jus finds that the door has been modified so that a key is needed from either side and he, not noticing this, (he failed his Wit CST to notice this "Hidden Thing") had set the mechanism to lock behind himself. He hurriedly picks the lock again. Check for Learning-by-doing since the time pressure that Jus is under constitutes a valid execution of his Skill. Jus closes the door behind him as he heads for the wide open spaces outside the building.

Let us consider the same character exploring the building when there is nothing behind the door. In this case, the Gamesmaster knows before hand that there is nothing in the cellar. He has also decided that anyone who picks the lock to get into the cellar can obviously pick to lock to get out and so a successful BCS roll to open the lock the first time means that the character will automatically succeed the second time. He does not tell this to the player and will still make him roll the second time to maintain suspense.

Jus arrives and picks the lock. The Gamesmaster with an abstracted comment about waiting to see if Jus will survive puts off temporarily the player's Learning-by-doing roll. Jus then using his Stealth Skill successfully reaches the bottom of the stairs and finds the cellar empty. Since there was nothing to sneak up on, his successful use of Stealth was not pertinent and he may not Learn-by-doing. Jus retraces his path to the door and finds himself locked in. Attempting to use his Picklock Skill to open it, the die result is 20. The Gamesmaster knows that the lock has been picked since that result was predetermined but he informs the player that "you don't seem to have picked it. The player in his frustration has Jus kick the door which amazingly (to him) comes open. The player is now allowed by the Gamesmaster to roll for Learning-by-doing for the lockpicking attempt.

STUDY AND SKILL IMPROVEMENT

The character's score in a Skill represents hard won and ingrained knowledge and/or abilities that the character has acquired. Thus, the skill represented by a Skill score is not gained by simple demonstration, casual reading or occasional practice. The character must diligently apply himself in order to make any significant gains in Skill score.

Study turns are stated to be of a week's duration. The Gamesmaster is free to alter the time period, but the Learning Rate of any characters involved should be altered to reflect the difference. The basic increase to a character's Skill score after a Study period of one week will be equal to his Learning Rate. This Learning Rate (his Wit Group) will be altered by various factors. These are presented in the Table of Learning Rate Modifications.

To his basic Learning rate, the character will add the value of any Learning Aids that are applicable. This number will be divided by the sum of the values of all the Learning Hindrances that apply. The result is the adjusted Learning Rate which is the number of points that will be added to the character's score in the Skill being Studied.

Any fractions that occur due to Learning Hindrances are retained during the period of Study. They are lost at the end of that period. Thus a character who has a month to Study and an Adjusted Learning Rate of 1 .7, will after four weeks, add four times the weekly rate or 6.8. Since the Gamesmaster has an adventure planned for the character, he is allowed no more Study time and the .8 is dropped from the amount that the character will add to his Skill score.

During a Study period, the only major functions (Research, Rebuilding, Using Influence are all major functions) the character may perform are related to learning. A character may Study two Skills, Study one Skill and Teach another or Teach two Skills. When a character is Studying two Skills during one Study period his base Learning Rate is Wit Group/2, nearest.

A Teacher may be any character, whether controlled by a player or the Gamesmaster, who has a Communicative Talent greater than zero. An ordinary Teacher has a higher score in the Skill being taught than any of the students. The score of the students may not exceed the Teacher's score while they are Studying under him. An Expert Teacher will have the maximum score in the Skill to be taught. A Gifted Teacher has a Communicative Talent greater than 10.

Some Skills require proper facilities in order to be learned at the normal rate. Combat Skills require the weapons to be used. Knowledge-based Skills require reference books. Equipment-utilizing Skills require the equipment that will be utilized. The absence of such things will act as a Learning Hindrance. It is up to the Gamesmaster to decide if proper facilities are available when characters are attempting to study a Skill.

When a character is Studying a firearm Skill, an expenditure of ammunition is required to prevent a Learning Hindrance. The additional expenditure of another unit of ammunition will act as a Learning Aid. Only one Learning Aid may be gained in this way during a Study week. The unit of ammunition will vary according to the firearm Skill being Studied. For non-automatic weapons five rounds are required to make a unit. Automatic weapons will multiply this figure by the average burst size of the weapon used to Study with. Heavy weapons require a three round expenditure.

TABLE OF LEARNING RATE MODIFICATIONS

LEARNING AIDS	VALUE
Expert Teacher	1
Gifted Teacher	1
Character's Governing Talent is greater than 10	1
Character is Studying a language in current local use	1
Character is Studying a firearm Skill & expends one unit of ammunition over the required amount	1
LEARNING HINDRANCES	
Solo Study (no teacher available)	2
Proper facilities unavailable	2
Character is studying an ancient language no longer in use	2
Character's Governing Talent for the Skill being Studied is less than 1	2
Character is acting as a Teacher during the Study period	3
The Skill being Studied is not a Freely Improvable Skill for the character	2
Character is Wounded for at least part of the week	2
Character is Seriously Wounded for at least part of the week	3
Character does not have the required score in a Prerequisite Skill	
Character does not make unit expenditure of ammunition while studying a firearm Skill	2
Optional Learning Hindrances	
Current Skill score greater than 50	2
Current Skill score greater than 75	
Once per week only.	
Study not allowed.	

OPTION INITIAL SCORE IN NEW SKILL

When a character Studies a new Skill and has a month's worth of Study period all together, he may acquire an initial score in the Skill rather than the value that would accrue through normal Study. Each Hindrance that applies will reduce the initial value by half. If the character would gain a higher score by using normal methods of Study, he may do so.

OPTION IMPROVEMENT OF ATTRIBUTES THROUGH LEARNING

Each time a character achieves another point of BCS, he may add .05 to the Governing Attribute. No value is received for the fractional scores until a full Attribute point is accumulated.

The Governing Attribute for a Skill is the one that appears first in the calculation for the initial score in that Skill.

It does not matter if the score sufficient for the increase in the character's Basic Chance of Success is the result of Learning-by-doing or Study.

OPTION INCREASE OF TALENTS THROUGH LEARNING

Each time a character reaches maximum score in a Skill, he has a chance of increasing his score in the Governing Talent. To do this he must roll 1D100 and consult the Reaction Table presented in Appendix of this Book. If the die roll indicates a "Good" or "Excellent" reaction the character will increase his score in the Governing Attribute by one point.

Harmon has decided he will Study Lockpicking Skill for the next four weeks. His current score is 32 and BCS is 6. Harmon's Learning Rate is 3. He is still mending from his last adventure and is Wounded during the first week which gives him a Hindrance of 2. Fortunately he was able to find a teacher. For the first week, his score is increased by 3/2 or 1.5. The second week he is no longer Wounded since he has fully healed in the previous week. This removes the Hindrance and the accumulated increase to his score is 1.5 plus the Learning Rate for the second week of 3 for a total of 4.5. The next two weeks pass in a similar fashion, adding a further 6 points for a final total of 10.5 points. Since the time allocated to study is over, the

decimal is rounded down to 10 points. His score in Lockpicking Skill is now 42.

If the Option for improvement of attributes is in effect, Harmon will add .1 to the governing Attribute of Deftness since he has increased his BCS by 2. (2 x .5 equal .1).

Later that year, Harmon acts as a Teacher for Sam in Lockpicking Skill. Sam's Learning Rate is 3 and he is only studying with Harmon. Harmon is also studying with a Gifted Expert Teacher in Safecracking Skill in which Harmon already has a score of 88.

Sam's Mechanical Talent is 11 and, since it is the Governing Talent for Lockpicking Skill, he receives a plus one to his Learning Rate. He is not suffering under any Hindrances and thus has a Learning Rate adjusted to 4 points per week. At the end of four weeks he would have a score of 16. If the initial score for a month's study Option is in effect, Sam's initial score would be Deftness + Wit + Mechanical. In Sam's case, this would give him 10 + 15 + 11 or 36. he would be allowed to have a score of 36. If Harmon had not improved his score earlier that year, Sam would have been limited to 32 points since that was the score of his Teacher.

Harmon beca use he is Teaching and Studying at the same time, will have a Hindrance with a value of 3. His base Rate is 3. The Gifted Expert Teacher adds 2 to the base. Since the Learning Rate plus the value of any Aids is divided by the value of any hindrances to give the adjusted Rate, Harmon will have an adjusted Learning Rate of (3 + 2)/3 or 1.7. After four weeks, this totals to a score increase of 6.8, rounded down to 6. His score is increased to 94. If the Attribute increase Option is in effect, Harmon will increase the Governing Attribute of Deftness by .05.

If Harmon had not been acting as a Teacher during those four weeks his Learning rate would have effectively been 5 and in four weeks he would have accumulated 20 points. This would have made his score 108. Since Safecracking Skill is a format 1 Skill, its maximum score is 100. Harmon would not even have had to spend the fourth week studying Safecracking Skill. He could have Studied something else and still perfected his skill. If the Option for improving Talents is in effect, Harmon would have a chance to improve the Governing Talent for Safecracking Skill which is Mechanical. Harmon's player would roll 1D100 and consult the Reaction Table. A die roll of 97 would be an "Excellent" result and Harmon could add one to his Mechancial Talent.

IMPROVING ATTRIBUTE SCORES

Attribute scores can be improved by diligent work over a Study period of one month. At the end of this period, the character will increase his score in the Attribute chosen by one point. Once a character passes certain breakpoints in the aging process, a die roll on the Reaction Table will be required. The number needed will depend on the character's age. The age to be considered here is the character's effective age. Use the Table below:

Characters effective age	Required to gain the point
Under 40	Automatic
40 to 49	"Mediocre" result
50 to 59	"Good" result
60 to 69	"Excellent" result
70 or older	die roll of 100

Supervision of the character's regimen by a character (it may be himself) with Therapy Skill will allow a character under the age of 40 a chance at a second point of increase. The character with Therapy Skill must make his BCS roll and the character in training must roll on the Reaction Table as if he were 40 years old and attempting to gain his Attribute point.

If the character is already 40 or older, a successful utilization of Therapy Skill will add the Effect Number (the die roll subtraction from the BCS) to the die roll on the Reaction Table.

Various drugs, herbal preparations and similar items or processes can have an effect on attempts to gain Attribute Points. These effects will be detailed when the specific item or process is presented.

EFFECTS OF AGE ON ATTRIBUTES

At the age of 40 characters begin to show the effects of aging. Once a character reaches 40, he will no longer automatically gain a point when he works to improve an Attribute. At four-year intervals beyond that, until he reaches 80, at which time the intervals are reduced to two years, he will undergo a round of aging. The effects are detailed below:

Age	Effects
44, 48, 52, 56	+2 to each Mental Attribute; -1 to each Physical Attribute.
60, 64, 68	-2 to each Physical Attribute; a Reaction roll is made and the results are interpreted as follows: Worse than "Bad" -4 to Mental Attributes "Bad" -2 to Mental Attributes "Poor" -1 to Mental Attributes "Mediocre" No change to Mental Attributes "Good" +1 to Mental Attributes "Excellent" +2 to Mental Attributes
72, 76	-4 to Physical Attributes; a Reaction roll is made as above to determine the effects on Mental Attributes, a -10 modification is made to the die roll.
80, 82, 84, etc.	-6 to the Physical Attributes; a Reaction Roll is made as above but a -20 modification is made to the die roll.

Modifiers to the Attribute scores are made to each of the Attributes of that type. If any Attribute is reduced to zero or below by the effects of aging, the character is considered to have died from old age.

IMPROVING OFF-HAND DEXTERITY

Off-hand Dexterity is treated as if it were a Physical Attribute for purposes of improvement and aging effects.

QUANTIFYING THE ENVIRONMENT

There are various factors present in the adventure environment that have to be quantified to deal with in terms of the game. These include barriers to the passage of a character or his projectiles, tools and their effects, and the dangers of such things as acid and fire. Each of these will be dealt with in this section. Any non-living thing that acts can be rated as having a BAP, an MNA and a PCA. This covers such things as elevator doors, strobe lights, falling bricks, etc. Such things can be designed by the Gamesmaster to suit the situation.

BARRIERS

Various materials are rated for a Barrier Factor. This number represents the barrier effect of 1 inch of the material. To determine the value of a barrier of something like a wall or a door, determine the materials that compose it and their thicknesses. Multiply each thickness by the Barrier Factor of the material and sum the results for all the materials involved. This will yield the overall barrier effect of the wall or door.

Any gunshots that hit a barrier will have their Bullet Damage Group reduced by the overall barrier effect. If the Bullet Damage Group is reduced

to zero or below the bullet will not penetrate the barrier. If it is not reduced to zero, any target struck will only receive the effect of the reduced Bullet Damage Group.

A muscle powered missile weapon will have its effective Strength Group reduced by 1 for each 5 points of Barrier Factor. This works in a fashion similar to the range effects on such weapons.

Hand-to-hand weapons which strike a barrier must succeed in penetrating a barrier. When the barrier is struck the damage done by the attack is assessed against the Barrier Factor. Any points in excess of the Factor may be applied as Damage Potential to a Location on the other side of the Barrier.

Fire against target behind an opaque barrier will be considered as if the firer were blind. Target behind a translucent barrier or targets whose position is essentially known (i.e., behind a firing port) will cause the firer to have a modification as if he were partially blind.

Some materials are considered capable of completely stopping projectile fire short of heavy weapons. These materials are identified by a in front of the Barrier Factor. The Barrier Factor for these materials is used for rating the strength of the material's resistance to attempts to break it down, dig through it or penetrate it with heavy weapons fire. Some of the materials listed below may not be present in a particular campaign but are listed here for convenience of reference.

When dealing with the demolition of a barrier to allow the characters access to the other side, the elimination of barrier points equal to the strength for the appropriate thickness of the material is considered to open a one meter by one meter space. A five or ten minute Tactical Turn is suggested. Some materials such as stone or metal, will not be penetrated by characters without the proper tools. Gamesmasters are advised to use their discretion.

BARRIER FACTOR OF MATERIALS

Material	Barrier Factor per inch
Glass	5
Glass, safety	20
Glass, shatter resistant	25
Heavy Leather	20
Light Leather	15
Metal, veneer	20
Metal, light	30
Metal, heavy	40
Metal, hardened or structural	*60.
Plastic, light	5
Plastic, medium	10
Plastic, heavy	20
Plastic, structural	*40
Sand	8
Soil	variable 8 to 20
Stone	*30
Wicker	10
Wood, veneer	5
Wood, solid	10
Wood, plywood	20

DOORS AND LOCKS

A door is considered to have a basic barrier effect equal to the Barrier Factor of the material times the thickness of the door. This has no effect if the door is opened. If the door is secured in some fashion, this barrier effect plus the barrier effect derived from the means by which the door is secured must be overcome in order to open the door.

Breaking in the door is accomplished by having characters roll Strength Ability Saving Throws. Up to two characters can attack a normal sized door at once. When a character is successful, he will roll his normal Effect Die. The results of the die roll are subtracted from the door's barrier effect. A character who rolls a one will add one to his Strength Group to determine the Effect Die for this attack only. A character who makes this type of attack against a door will take one point of subdual damage. A die roll of 20 will cause the character 1D6 of subdual damage. When the total of the Effect Die rolls exceeds the barrier effect of the door it has been broken down.

Such attacks may be directed at the means of securing the door, if it is known and the die roll for the character's attack falls in his Critical Saving Throw range. If the die roll falls in the Ability Saving Throw range, the overall barrier effect is attacked instead. Should the barrier effect of the securing method be overcome before the overall barrier effect is reduced, the method of securing the door (lock, crossbar, wedged chair, etc.) will be presumed defeated and the door may be opened.

Locks are rated in three ways: by type, complexity, and barrier strength. The type of lock will indicate what Skill the character will need to overcome it. The complexity represents the amount of difficulty the character will have in overcoming it. The barrier strength is the amount of barrier effect the lock will have when used to secure a door.

Standard locks that open with a key require Lockpicking Skill to overcome. The complexity of the lock will be subtracted from the Character's Basic Chance of Success. Each time the character makes a successful BCS roll, he will roll the Effect Die for his Deftness Group. This is the amount of the lock's barrier strength that is reduced. When the barrier strength is reduced to zero or below the lock will be open.

SAMPLE LOCKING MECHANISMS

Mechanism	Skill needed	Complexity	Barrier Strength
Small key lock	Lockpicking	0	5
Standard key lock	Lockpicking	1-3	10
Heavy key lock	Lockpicking	1-6	20
3 digit combination	Safecracking	0-5	10
3 digit heavy combination	Safecracking	1-5	20
4 digit combination	Safecracking	1-10	20
Bank vault	Safecracking	11-16	50-200
Digits in combination locks can vary greatly			
Wedge chair	None allowed	—	10
Crossbar	None allowed	—	varies by size and material of bar
Rusted mechanism	None allowed	—	5

Combination locks require Safecracking Skill. One successful BCS roll is required for each digit in the combination. The complexity of the lock is subtracted from the character's Basic Chance of Success. Once each number of the combination has been derived, the lock is open. No barrier effect need be overcome.

Specialized forms of locks may be present in the campaign. These will be presented along with the skills needed to overcome them later in the rules. For now a simplified selection of sample locking mechanisms is presented below.

The time involved in attempts to break down a door or pick a lock will be highly variable. It is left to the Gamesmaster to decide just how long an attempt will take. In general, the time required to make an attempt to bash a door will be less than the time required to attempt to pick the lock. Only a few seconds are required to hurl yourself at a door but five minutes spent working at picking a lock which is not particularly complex is not unusual.

TOOLS AND THEIR USE

In general tools are designed to make a person's work easier. The use of the proper tools in any of the operations mentioned above will enable the character to have a greater effect against the barrier impeding him. Levers, such as crowbars, will act as multipliers of a character's Effect Die roll when attacking the barrier effect of a door. Lock picking tools can give a modification to the BCS and act as a multiplier to the Effect Die roll of a character picking a lock. A device to increase the hearing of a character engaged in opening a combination lock will increase his Basic Chance of Success. A shovel will act as a multiplier to the Effect Die roll for a character who is digging in the earth. The exact effects of the tools that are available will be given in the equipment lists in Book 2.

The characters have found a one half inch thick door of oak. It is closed and locked. Unknown to them the door is also barred on the other side by an inch thick iron rod. The door is a heavy wood (Barrier Factor of 10) and is one half inch thick for a barrier effect of 1/2 times the base Factor. This yields a value of 5. The bar is of a heavy metal and is one inch thick and so will add its Barrier Factor to the overall effect. This is 40 and so the total barrier effect is 50.

Harmon the Picklock attempts to open the lock using Lockpicking Skill. His BCS is 8, the complexity of the lock is 0 and will have no effect on Harmon's BCS. The die roll is a 10. So the

Gamesmaster declares that after five minutes Harmon still has not opened the lock. Harmon tries again. This time the die roll is 4. Harmon will roll the Effect Die for his Deftness Group. Since his Group is 3, Harmon will roll 1D10. The result is 1. He is using high quality professional lockpicks and these will multiply his result by 2. This gives an accumulated effect of 2. The lock is still not open but it is on its way. If the characters attempt to bust through the door at this point the lock will still add its full value to the barrier effect. Harmon continues. A die roll of 7 indicates success again. The Effect Die result is a 6 this time and the multiplier of the tools is not even needed. The lock is open. Harmon smiles and turns the handle. The smile fades

when he discovers that the door will not open. They must resort to bashing the door down to get through.

The door has its overall barrier effect reduced by the value of the lock to 45. Jo (STR equals 32) and Sal (STR equals 15) attempt to bash the door. Each rolls a Strength AST. The die rolls are 12 and 3 respectively. Both have succeeded. Each rolls the Effect Die for the proper Strength Group, 2D6 and 1D10 respectively. The results are 10 and 5 for a total reduction to the barrier effect of 15. The door is still in place. Again they try and again they succeed. This time the Effect Die rolls are 8 and 4. The barrier effect has been reduced to 18. A third attempt has Jo succeeding and rolling an Effect Die result of 9. Sal rolls a 20 on the Saving Throw and takes 1D6 of subdual damage. The barrier has been reduced to 9 points. They try again. This time Jo misses his Strength Saving Throw. Sal however rolls a 1. This allows her to raise her effective Strength Group by 1 for determining the Effect Die. For this attempt she will roll 1D10 instead of 1D6. The die result is 9 and the door is burst open. Since they have made four attempts, each character is given 4 points of subdual by the Gamesmaster. Sal, having rolled a 20, takes an additional 1D6 of subdual damage points.

If the characters had elected to fire a bullet through the door, the BDG of the round would have only been reduced by the barrier effect of the door itself (5).

FIRE AND ITS EFFECTS

The rules concerning fire will deal primarily with its use as a weapon. Fire is rated as having a strength group based on its initial temperature range at first exposure. From this strength group rating, an Effect Die will be derived in the usual fashion. A low temperature flame, such as an alcohol flame, has a rating of 2. A normal fire has a rating of 3. While a high temperature flame (temperature greater than 200 degrees Centigrade) has a rating of 4. Simple application of a flame will cause no significant effects unless the Armor Value on the target Location is exceeded by the Effect Die roll. Then the effects will vary by the type of material involved. Continued exposure will have varied effects depending on the type of protection being worn. The result of a Critical Hit by a character armed with a fire weapon will be that the target Location will be subject to the rules for continued exposure beginning on the bookkeeping phase of that Combat Turn. Damage by fire is lethal damage.

FIRE AND ARMOR MATERIALS

For the purposes of how they are affected by fire all armor materials are broken down into groups. The basic two are Non-metallic and Metallic. Some campaigns may have other classes of material such as Plastic, Magical, etc. The reaction of such types of materials will be presented along with the other specifics regarding the particular type of material.

Non-metallic materials will stop damage from an applied flame in the usual fashion. If however, the Damage Done by the flame attack is greater than twice the Armor Value of the material, it is considered destroyed beginning on the next phase. If the rating of the flame exceeds the Armor Value on the Location, the character is considered to have caught fire and will be subject to the rules for continued exposure.

For each turn of continued exposure, the fire will increase its strength rating by one before determining its Effect Die. Armor will not protect a character who has caught fire. A character may extinguish the flame by falling to the ground and rolling about. This requires a full Combat Turn of activity. A character will reduce the rating of the flame by his Maximum Number of Actions. If he begins the process in the middle of a Combat Turn, the reduction will be equal to the number of Actions the character could still perform in that Turn. This reduction of the fire's rating takes place before the fire's rating is increased for that Turn. Once the rating is reduced to zero or below the fire is considered out. If a character is ignited in more than one Location, only the strongest flame need be extinguished although both will cause damage to the character. Any characters aiding a victim who is on fire will add to the chances of extinguishing it. Their ability to reduce the fire's strength is the same as if they were trying to put out a fire on themselves. Any character attempting to aid a burning character will be subject to an attack by the fire at one less strength rating if the fire is not out at the end of any turn on which the helping character is involved in the process.

Once the fire is out, all non-metallic materials will have their Armor Values reduced by the highest strength rating the fire achieved.

Metallic materials will resist the effects of an applied flame as they would any normal attack. They will not ignite nor will they be destroyed by the flame.

On continued exposure to fire, they will provide protection from damage until such time as the Effect Die roll of the flame exceeds the Armor Value. After that point, metallic material will provide no protection from fire damage

until it is cooled. Once the fire is extinguished (see above) the material will continue to cause damage as if the fire was continuing at its greatest strength. On each turn starting with the bookkeeping phase of the turn on which the fire was extinguished, the strength rating will be reduced by 1 and the correct Effect Die roll will be made. When the fire's strength is reduced to zero the armor is considered cooled off. Cooling agents such as water may be used to hasten the rate of cooling. The exact effects are left to the discretion of the Gamesmaster. After the fire is out and the metal has cooled, all Armor Values will be reduced by the greatest strength rating achieved by the fire.

If the character's whole body is exposed to flame the Average Armor Value is used to defend against the fire. His armor material is considered to be of the type that covers the greatest number of Locations.

FIRE AND BARRIERS

Fire will attack barriers that are composed of combustible materials. On each turn of continued exposure of the barrier the fire's rating will be increased by one Group. When the cumulative total of the Effect Die rolls exceeds the barrier effect, the barrier will have burned down. The fire will continue to burn on successive turns with its rating being reduced by one Group each turn until it reaches zero, at which time the fire will extinguish due to lack of fuel. It is suggested that a Gamesmaster use a Tactical Turn of 10 minutes in calculating the effects of fire used against barriers.

SMOKE AND ITS EFFECTS

Smoke will affect visibility and act as a narcotic poison with a serious effect at the Crisis stage. The rating of the density of the smoke is left to the Gamesmaster as the variables due to air flow, materials being burned, concentration, etc. are highly dependent on the situation.

A density of one yields Dim Light conditions; two yields Poor Light; three yields Darkness; and four results in effective blindness. If light conditions are already less than perfect, they will be reduced further by the number of steps equal to the smoke density.

Smoke, as a narcotic poison, has an Aerosol Vector. Its strength is equal to its density. It has an Incubation Period of a number of Combat Turns equal to the character's Health Critical Saving Throw minus the density of the smoke. No specific Attributes are attacked. The Cycle time is one Combat turn. Once the character reaches the Crisis stage, the poison will continue to attack by causing subdual damage to the character equal to the result of the Effect Die roll. When the cumulative total of these subdual points exceeds the character's Damage Resistance Total the character will die of smoke inhalation. Removal of the character from the smoke will halt the process at whatever stage it is in. A Health Ability Saving Throw, attemptable each Combat Turn, will allow the character to throw off the effects except for any subdual points received after the Crisis point. This subdual damage may be healed in the normal way.

ACID AND ITS EFFECTS

These rules deal with the effects of a strong acid, or for that matter a strong base, on a character/or his clothing and armor. Acids are rated for their strength and have the equivalent of an Incubation Period.

When a character gets acid on his person, it will have no effect until the end of the 'Incubation Period.' Once that period is over, the Gamesmaster will roll the Effect Die for the Group corresponding to the acid's current strength. The die result will indicate a reduction in the Armor Value of the material covering the target Location. Once the Armor Value is reduced to zero, the character will take any further points as lethal damage. The armor is permanently destroyed. The acid will continue to attack in this fashion on the bookkeeping phase of each Combat Turn. After each attack the strength of the acid is reduced by 1. When the acid has a strength of zero the attacks will stop.

At any time, the application of a base will reduce the strength of the acid by its own strength rating.

If a character is struck in Location 2 by acid, some special effects may occur. If the character has no protection from the fumes, he will be subject also to an attack of the acid as a Lethal, Aerosol Vectored poison. This poison will have no Incubation Period, a strength equal to the strength of the acid minus one and a Cycle Time of one Combat Turn. The poison has no target Attributes. See the section on poisons on page 41 for the mechanics of dealing with poison. A character will be partially blinded during the period that the poison is active in his system.

If the character takes damage to Location 2, he will be subject to a roll on the Acid Special Effects Table. Any damage done to that Location will be added to the result of the roll of 1D100 and the result checked on the Table.

ACID SPECIAL EFFECTS TABLE

D100	Special Effect
01-30	No serious effect
31-60	Extensive scarring. Decrease the character's Looks category by the strength of the acid when it began its attack.
61-70	Character's sense of smell is impaired.
71-80	Character's sense of taste is impaired. Character will also have a speech problem.
81-90	Character is blinded in one eye.
91-95	Character is blinded in both eyes.
96-00	Roll twice for effects ignoring die rolls over 95.

It is left to the Gamesmaster to adjudicate the result in subsequent adventures of the character's impairment in smell, taste, hearing or speech. Other effects are self explanatory. In all cases, the character will be left with sufficient scars to be considered a distinguishing mark.

SPLASHING RESULTS

When a character is hit by a flask of acid, flaming oil or some other such nasty thing, it will affect the target Location and 0-2 contiguous Locations. The number of Locations is determined by rolling 1D3 and subtracting 1. The exact Locations are to be determined by the Gamesmaster according to the circumstances and the position of the character being struck.

When such nasties impact on the ground they will affect the target hex and 0-2 additional hexes. The first additional hex will be in the line of the throw. There is a 50% chance that the second will also be in the line of the throw. Otherwise it will be adjacent to the first hex of splash. See illustration. Such things will spread further on the next Combat Turn unless eliminated by dousing or counteracting. The second turn spread will be to all hexes contiguous to the original hexes and have a rating for strength equal to the nasty's current strength minus 1. If this reduces the strength to zero there is no spreading effect.

EXAMPLES OF SPLASH AND SPREAD RESULTS

- T - Thrower
- V - Target
- L - Landing hex due to miss
- - Line of trajectory
- S1 - First hex of Splash
- S2 - Second hex of Splash
- ▨ - hexes of spread each Combat Turn

2 HEX SPLASH IN LINE OF THROW

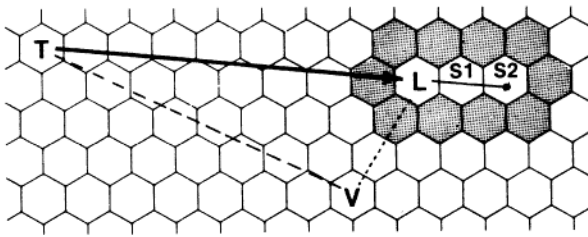

2 HEX SPLASH WITH SECOND NOT IN LINE OF THROW

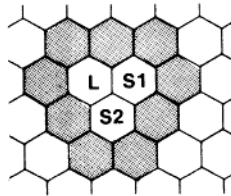

1 HEX SPLASH

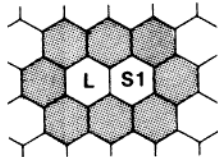

0 HEX SPLASH

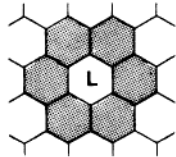

ON BEING A PLAYER

Your old buddy, Joe Gamesmaster has invited you over one evening for a session of something called a "Role Playing Game" Whassa Role Playing Game? When you get there, Fred and Charley are sitting on the sofa, talking about last week, when they opened the door and killed 4 or 6, nowaitaminnit, did they say ORCS? Joe is sitting in a corner, half buried behind a wall of papers, charts, graphs, and assorted stuff, punching his calculator and fiddling with some little plastic doodads that look like weird dice (at least he is rolling them and looking at numbers on their sides). Of course, he always was into weird cults. Maybe this is a new religious kick. What you don't see, and this puzzles you, is a board, darts, hockey sticks, a catcher's mitt, or anything else to give you a clue as to just what kind of game a "Role Playing" is. You may, at this point, be justified in whimpering, "NOW what have I gotten myself into?"

Well, it actually isn't as bad as that. First thing, if Joe is a hardshell Gamesmaster, he probably has explained what Role Playing is until you're ready to slug him. In any case, he probably filled you in over the phone, and you know how such games work, to a degree. If not, then read the introduction to Role Playing in this book, page 1. What we are going to look at with a bit more detail here is just what your job is, as a Player in an on-going Campaign.

READ THE GAME

It is probably a good start to skim through the rules, if you haven't done so yet. You probably can't read the whole thing yet, as parts of the Game are "For Gamesmasters Only!" Pay particularly close attention to rules on how to design a Player Character, because that is your first big job in any Role Playing Game.

BEING BORN

Ideally, the Gamesmaster should hold a special "Character Design" session before presenting the Players with their first adventure, or "Scenario." At this point, he and his Players go over the basic rules, clear up any overall questions on procedure, and design at least one Character for every Player. It is probably advisable that each Player have two Characters to start with, so that a "sad mishap" part of the way through the first scenario will not leave the Player with nothing to do for the rest of the evening. On the other hand, it may be desirable to limit the first adventure to one Character per Player.

This will permit the participants to concentrate on properly handling their figures without trying to keep both Characters going at the same time. The final say on the "Character to Player" ratio for a given adventure is the Gamesmaster's.

The first step in building a Character is quantifying his physical and mental traits. This usually includes such characteristics as physical strength, reaction speed, intellect, and so on. Some games assign a random score, rolled on dice, to these areas. Other, including this one, give Players a basic number of points which they may allocate among the Character's traits pretty much as they please.

The idea behind this system is to permit the Playerto build what he conceives to be the "ideal" hero. It will soon become apparent that you cannot make the Character above the average in one area without putting some other Attribute below the norm. See page 4 of this book for the detailed rules on designing these physical and Mental "Attributes."

In designing your early Characters, it will be wise to try and foresee just what abilities a high score will "buy" you, not to mention what a low score will do to your Character's survival potential. It is unlikely that you will come anywhere near an optimum design in the early stages. Of course, it can be interesting to construct a Character who is markedly low in some areas, with near-superhuman scores in others, just to see how far he gets. If the Gamesmaster permits multiple Characters on one Adventure, fascinating results can be obtained by designing a team: two Characters who between them comprise a mix of high scores, in the tradition of Fritz Leiber's Fafhrd and the Grey Mouser.

After setting the basic Attributes, most Games, including ours, will derive certain secondary traits from these scores. We call these "Abilities." Again, the Player should familiarize himself with just what these Abilities control in play, so that he can fiddle them into acceptable shape. Discovering that you really murdered some Ability score may cause you to go back and adjust the Attribute allocation, This is perfectly legitimate at this stage of the game.

In our Game system, the next stage is the generating of the "Talents," inherent aptitudes on the part of the Character. The rules governing Talents

are on page 7 of this book, but as stated there, the manner in which the scores are generated are Campaign dependent, to be found in Book 2. The Gamesmaster may have altered this system to fit his particular Campaign, and this should be checked first. Again, as you allocate the Talent scores, try and foresee how they will affect the Character you want to portray. A hardened warrior will, or should have, a significant Combatative score. The scholar will have a high score in Scientific and Communicative talent, and so on.

The basic process of "being born" as a Character covers all of this preliminary allocation of scores to the Attributes and Talents, and the derivation of the dependent Abilities. It provides a rough picture of the physical and mental nature of the Character.

GROWING UP

The next step in Character design takes the Player through what we call the "Pre-Adventure" period. This can be fairly detailed, providing for the social standing of the Character, his early training in schools or military service, or what have you. Or it may be an abstract, generating a given number of years, and the things acquired in those years, which the Player may turn into Skills, knowledge, and cash. Again, the final form is Campaign dependent, and options should be checked with the Gamesmaster.

Opportunities will exist to improve the Attributes, and to acquire Skills. See page 11 of this book for a description of skills and how they work. It is at this point that the Player needs to really think out the question of what he feels this Character is like: what personal goals has he set for himself, what were his formative years like? Should he concentrate on the Combat Skills, having the Character begin to acquire mastery of the arms of his culture? Or is the Character more studious, a scholar of the mysteries of nature, science, and philosophy? has he studied the arts of the thief, mastering locks and stealth, or, if the Campaign admits of such arts, the dark knowledge of the occult? In other Games, the usual technique is to have the Player assign his Character a profession, which defines the Skills available to him. We offer the ability to pick freely what areas your Character can enter, and in the future, if he lives, he can branch out into other, unconnected, fields of endeavor.

Upon finishing the Pre-Adventure, the Character is fully designed on the outside. He will have achieved his fullest development in his inherent and acquired capabilities, and can only go further after entering the danger fraught world of an adventurer. There will remain only one step more.

GETTING YOUR HEAD ON

As mentioned on page 2, it is the view of the authors that enjoyable Role Playing implies that the Player tries to think like the Character while playing, reacting to events as he would. To do this consistently, implies that the Player has put some thought into the psychology of his Character.

Now, from the design of Attributes and Talents, along with such ancillary data as physical appearance and size, the Player has a decent picture of what the Character looks like. From the Pre-Adventure, he knows what areas the Character has studied, what abilities he has specialized in. As stated earlier, the hinge-pin of all these earlier decisions is the question "what do you want the Character to be able to do?" Putting all these factors together, the Player can begin to move in on the concept of what kind of person his Character is.

The usual pattern we have seen in playtesting indicates that, at first, Characters tend to be very like the Player who design them. But soon, for various reasons, there will spring up a crop of Characters with unique personalities, sometimes diametrically opposed to the Players own values. One of our playtesters has a Character of long-standing, initially a fairly benign if not overly brave type, who committed an act of cowardice in a tight spot. Surviving the ordeal by these means, he has since developed a number of curious traits by betraying his initial principles, and now is quite powerful, but at the cost of his humanity. The Character in question now is motivated by a series of values foreign to the Player who designed him, and is tormented by the conflict between what he was and what he is. The psychological price of his achievements in terms of inherent human characteristics has generated some actions in play which revolt the other participants. But the adventures of this figure are fascinating, and his saga is not dull. If his dilemma does not destroy him, his future promises to be equally interesting.

Now that case evolved as a Character found his original values unstable in the face of stress. Since then, Players have reported equally interesting results to be obtained by designing Characters who are, from the outset, completely unlike themselves, even Characters whom they find unsympathetic, but who fit a heroic image that interests the Player. This is an attitude that should be encouraged. If Role Playing Games have a value beyond sheer entertainment, then it is in this: Players are given some insight

into the workings of human psychology under stress, and hopefully come from the experience with a better and more tolerant understanding of how they and theirfellows respond to such stimuli.

So it would seem that the effort to take a half hour or so and work out the basic values for the Characters is well worth while. And even if the Campaign situation is best served by betraying those values, the Player will find it more enjoyable to try and work out a solution in a manner suitable to the

Character's personality than one which merely follows the dictates of expedience. The Gamesmaster should reward such consistency of Play in subtle but suitable ways.

BEING A HERO

One thing about Role Playing Games that can confuse the new Player is the fact that the Games never end, there is not real way to lose, except to die, and no final winner, except those who survive. Sometimes even a Character's death can be a victory, if it is heroic.

It is necessary to understand that the essence of Role Playing is autobiographical. Players and Gamesmaster are combining to "write" the life history of the Characters, who are presumed to be heroic in stature. A biography may be episodic, with the high points of the subject's career providing plateaus in the storyline, but the book never ends until the subject is dead. In a full Campaign, where Players have other Characters operating, the loss of one particular figure ends his story, but there are others ready to fill the gap, with ongoing sagas of their own, and the overall flow of things is not interrupted.

In order for the Characters to develop along these heroic lines, it will be best form the Campaign to all epic scope. Not that it need encompass huge territories or immense conflicts, but the challenges to the heroes must allow them to face and overcome greater-than-normal challenges, just as their training gives them greater than normal potential. A reading of heroic literature will provide the Gamesmaster and Players with a view of what this entails. We might suggest:

- The Iliad and Odyssey of Homer
- Malory's Morte D'Arthur, and the related Arthurian works of de Troyes and the trouveres, and von Eschenbach and the minnesaenger.
- Modern heroic fantasy, in all its legions, led by Robert E. Howard, Poul Anderson, "Alan Burt Akers," Michael Moorcock, Fritz Leiber, Roger Zelazny, et al.

All of these, and other works, illustrate the concept of the hero in a vital and entertaining manner, and the sensitive reader will come away with a powerful impetus in his playing style, with the all-important realization that death only hurts a little, and glory lives on forever.

It is easy to slip into a one-dimensional value system in a Role Playing Game. The term "hero" embraces the "Bad Guys" as well as the Good. The latter can be narrow-minded, callous, self-righteous and vindictive. Galahad, in the various Grail legends, is such a one at times. "Villains" contrariwise, can be generous, brave, noble, merciful to foes, honest and honorable. Observe the traitor, Lord Gro, and even his necromantic master, King Gorice of Witchland, in Eddison's The Worm Ourobours. The greatness of heroes is proved only when they fight equally great villains.

So let the Players demand the utmost of the Gamesmaster in the challenges they face, and as long as he keeps the abilities of the Player-Character in mind, let the Gamesmaster in kind. Apply courage, cunning, and honor in equal parts when playing, according to your Character and the Campaign, and even if you lose, you will win the Game. Because played in this light, you will find it an exhilarating and cathartic exercise in imagination and vicarious excitement. And that is how to really win in Role Playing: ENJOY!

ON BEING A GAMESMASTER

To a new Gamesmaster (and often to an old one) the demands of the job can make the strongest quail. To be in sole charge of the way a given group plays the Game, tormented by doubts as to whether one is doing it "right," whether the Players are enjoying it and what to do for the next Adventure. It's enough to give you gray hairs!

Any Role Playing Game depends in large measure on the Gamesmaster. The rules cannot be written to cover every case in detail, and they should not be. The flexibility to meet any demands placed upon the Game system by the requirements of the Players and Gamesmaster is what gives a Game its attraction. For the rest, lots of notepaper, a good imagination (with some cribbing from genre literature), and patience all stand the Gamesmaster in good stead.

This overview of the Gamesmaster's task is broken down into three broad areas:

Before Play: The work involved in setting up the Campaign. Planning individual scenarios for Adventures.

During Play: Running a playing session. Fairness doctrines. Secrets and mysterious events. Running Non-Player Characters properly.

After Play: Effects of successful Players on the Campaign. The "Experience" question. Housecleaning the Campaign.

We will be dealing in generalities in this Section. Specific cues to Gamesmasters for this particular Game will be found in Book 3. Our goal here is to help the Gamesmaster get a handle on how to organize his work with this (or any other) Game, to set up a working Campaign with the minimum of wasted effort or frustration.

BEFORE PLAY

Let's assume you have never run a role Playing Game before. You have a nice, new Game, not an hour out of the store, box just opened in front of you. Now what?

READING IT

Quite seriously, the first thing to do is read it. Start with whatever book is labelled #1 and skim through the whole thing, all the books in order. Don't try to bash your memory into retaining all the details at this point. Try and get an overall picture of the following:

- What kind of fantasy setting(s) is/are appropriate for this Game?
- Does it lack anything I really want to see done?
- How do individual Characters work in the system?
- Does it offer any helpful hints to the Gamesmaster in the rules?

Now, you probably would not have bought the Game unless you wanted to run a Campaign based on what it simulates. But you won't really know how it operates until you have completed this first read-through. If you have bought something suitable for Musketeers in the hopes of using it to set up a Wild West Campaign, you missed something somewhere.

If the Game has the potential to do what you want, then you are halfway home. Next we look at what specific rules it has, what it might have left out, and what rules you don't care for (too sketchy, too complex, boring etc.). If the rules do not cover something you wanted in the Campaign, then you will need to look elsewhere, either by combining two rule systems or else designing the rules yourself. Many Gamesmasters find this latter course more rewarding.

Pay attention to the way Characters are designed and operated in the Game. These figures, after all, are the principle medium by which you and your Players will interact. The first thing you will have to help Players do is design at least one Character, and you will also need to prepare your own Characters to people the Campaign's various locales before actually playing.

Now re-read the basic rules for common actions in the Game: such activities as fighting, movement, acquiring and using Skills, etc. The contents of this Book will provide that information for this Game. You should know how such things work in some detail, so that a Character can have a fight or cross the street without your needing to look it up in the rules.

But do not let this proviso override common sense. Never hesitate to call a halt in play to look up some rule you are unsure of. The little time lost then will save a lot of time (and emotion) later on when someone questions the events of 10 minutes ago as being different in the rules. Another suggestion: Always let players know in advance if the basic rules for the game have been changed to some variant system. This does not mean you should tell them that a weapon or trap not documented in the rulesbooks is lurking around the corner. That is part of your Campaign and the Players can only find out about it by experience. But if you have designed an alternate method of Combat, the Players MUST know how it operates if they are to use it properly

Lastly, re-read this type of article, aimed directly at giving the Gamesmaster a grasp of how to operate. If you disagree with some suggestion, ignore it. Also read examples of play especially those written to show what the action looks like from the Gamesmaster's point of view.

PLANNING THE CAMPAIGN

Once you have a grasp of the rules, it is time to start considering the Campaign you intend to build.

This is the very heart of being a Gamesmaster: creating the fantasy "Campaign" wherein the Player-Characters will vie for heroic honors.

First, consider the overall "color" of the Campaign. This is in many ways a question of period. In some Campaigns, Gamesmasters have decreed a

great mix of cultures. but many prefer their Campaign to center around a specific time in Earthly history (or the history of their particular world) if only to keep the possibilities of the Campaign a little more under control.

Decide roughly in what period your Campaign is set, this will provide many leads as to details of dress, weaponry, armor, and what Skills and equipment are available to the Characters. The next step is to outline the society in which the Characters live. If your Campaign is indeed on Earth, and in a historical period, a bit research in popular histories or even well-written historical novels will provide all the background you are likely to need. If you are designing an "alternate" Earth, or a fictional world, you can construct the culture to fit your needs. If you are designing a Campaign to fit a particular fictional world from your favorite books, the source works will provide the atmosphere you want.

Slavish concern for historical accuracy is not necessary. If you want to build a Campaign on Earth history, do not feel you must be absolutely faithful to what was. Often, greater pleasure may be derived in a Campaign based on what should have been. The classic example is King Arthur's Britain, which should, historically, be set in a Romanized Celtic society around the 7th century. However, most Role Playing Games for Arthurian England are set in the high medieval (14th century) which was the environment used by Malory in his *Morte d'Arthur*.

What is good enough for literature is surely good enough for gaming purposes.

THE SCENARIO

Once you have the background for the Campaign, which can be as diverse or as limited as you wish although having capacity for expansion as the Campaign proceeds, it is time to turn to the first in a series of design tasks: the scenario.

A scenario is the outline of an Adventure in which a group of Player-Characters are going to try and accomplish some goal. This can be fairly open or very specific. The Classic Example of the open scenario consists of sending the party into an elaborate "Place of Mystery," (a haunted castle, lost city, derelict starship, or some other place of treasure and danger) to try and survive while they loot the place. Such scenarios are useful, since once the initial design work on the place is finished, it can be used over and over, until looted out. The problem with open scenarios is that if they are all the Players can tackle, the Campaign tends to get into a rut.

Specific scenarios might be described as "missions." The Player-Characters have some task to perform. Rescuing the kidnapped princess, bearing the vital dispatches to General Garcia, running Damnation Alley with a truckload of anti-plague serum, are classic literary examples of specific scenarios. The advantage is that such adventures give the Players a definite goal to achieve, and permit the Gamesmaster to write a somewhat more detailed storyline. Their main disadvantage is that once accomplished, the scenario cannot be tackled again by the same players.

DURING PLAY

Once the Gamesmaster has a comfortable degree of familiarity with the rules and has prepared a scenario (or decided to use the starting scenario enclosed with this Game), then he is ready to invite the Players over for a session.

It is advisable to get your Players together prior to this first adventuring session in order to go through designing a Player-Character, to get the Characters outfitted, to orient Players to your Campaign's history and culture, and to answer questions about the gaming process. If the Players have not bought copies of the Game, they will need to read this book and also Book 2, as well as any other reference materials aimed at the Players. Under no circumstances should players read Book 3 or other material marked as sacred to the Gamesmaster! They may have read these materials on their own, if they also own copies of the Game, but this should not happen during playing time. If something occurs to allow Players direct reference to some information in Book 3, or other such restricted material, the Gamesmaster can either read it to them, jot down a note, or allow them to look up the particular reference.

So, Characters ready and armed with knowledge of their World, the Players wait for the scenario to begin. This can be accomplished in an infinite number of ways. Gamesmasters have been known to offer the opportunity to undertake a scenario as a commission from mysterious, cloaked figures. or by shanghaiing the Player Characters onto a ship which eventually runs aground on a certain uncharted isle, or otherwise contriving to put the adventure in their path, or conversely, put the Characters in the adventure's path.

Sometimes the Players miss the clues and walk right by the opening of the scenario. A creative way to nudge them into the correct approach can

usually be improvised. Failing that, the Gamesmaster always has the option of pointing out the error to the Players. Again, some Players take one look at the horrifying prospect presented by the scenario's beginning and decide they want no part of it. This can cause problems, and often occurs early on in a Campaign, before the Gamesmaster and Players are at home with each other. This leads us to the whole question of Player enjoyment.

ENJOYING THINGS

There are no compelling reasons for playing games if the participants do not enjoy themselves. We will not presume to try and define just what appeals to you in Role Playing. The attractions are so varied that it is not really material what turns you on to them. What is germane is the need for empathy among the gainers. If the Players really loathe some type of situation, it behooves the Gamesmaster to think long and hard about using that element of the Game in his Campaign. If the Players are eager to tackle some particular type of adventure, then the Gamesmaster is well advised to quietly draw up a scenario along those lines.

But Players should not dictate the course of the Campaign. That is the Gamesmaster's domain, and the fun he has planning things is the recompense he receives in lieu of the swashbuckling his Players get to indulge in. If the Gamesmaster plunges the Campaign world into a war, or interdicts travel in certain areas, it is improper for the Players to gripe at him for it. And, just as their Characters may decry fate to no avail, so shall Player complaints about such matters come to naught.

The touchiest situation in Player-Gamesmaster relations arises when the Players can justly complain that the Gamesmaster is being unfair. Not in the sense that "Fate" is unfair when random events plague their Characters, but that the Gamesmaster is deliberately fudging things so that the Characters lose (i.e. die during adventures). The converse is equally ugly: when the Gamesmaster suspects or proves that somebody among the Players is deliberately cheating.

The former situation can be due to oversight by the Gamesmaster ("Come to think of it, that really was too rough") or a common point of view in Role Playing which we feel is not conducive to enjoyable gaming: when the Gamesmaster feels he is competing with Players, and "wins" if he can kill off as many Characters as possible. The Gamesmaster should preserve a detached view of the Campaign's progress. What good the Players have accomplished should be rewarded. If they have accomplished something particularly dumb, it should be its own punishment with no extra salt rubbed into the wounds by the Gamesmaster.

When Players are deliberately cheating, the rest of the group must exercise its best judgement. If the offender shows no signs of correcting his behaviour, then he must obviously be barred from further play. Be careful not to jump to the conclusion that someone is trying to pull a fast one when it may be that he is misunderstanding the rules. When something happens in play that should not have occurred under the rules, the Gamesmaster and Players should calmly examine the result. If it is possible to roll the action back to the point where the error occurred and pick it up from there, this is the best solution. If such a decision will adversely affect the session's play, it is probably best to let things stand. Patience and rational discussion will serve all concerned much better than unfounded accusations. This is a GAME: that implies that it is not worth playing if the rules are not followed, but likewise should preclude severe emotional upsets if things do not always go smoothly. In any case: The Gamesmaster has the FINAL word in resolving all questions of procedure during play.

RUNNING THE SESSION

There can be no hard-and-fast rules for the Gamesmaster in the details of running a playing session. Campaign activities will bear the imprint of his own personality modified by the Players who interact with it.

The usual manner in which a session in a Role Playing Game runs is as follows: The Players choose their Characters for the scenario to be played. This may be a fairly free choice, especially in the early days of the Campaign, or may be restricted by who is "in town" at that point in the Campaign's calendar, or "Time Line." The decision may also be controlled by the past history of the Character(s) involved. In any case, the Players select the Characters suited to the scenario and attend to any outfitting they need and can afford. This is also the time when the Gamesmaster will need to start filling them in on advance information (if any) for that scenario.

Once these preliminaries are completed, the adventure begins to move. The Players know their Characters are pushing beyond the boundaries of safety and civilization and into the realm of imminent danger and fantastic encounters. The gloves come off.

The progress of the adventure is conducted by telling each other what is happening. The Games master tells the Players what is happening around

their Characters, and the Players respond by telling the Gamesmaster what their Characters are doing as a result. Players can ask questions, seeking further information about their surrounding or the events confronting them. The Gamesmaster can answer with more detail, relevant clues, irrelevant facts that are indeed evident but have no bearing on anything important. Players cannot ask for information beyond the reach of their Character's senses or knowledge. A classic example is along the lines of:

GAMESMASTER: You enter the building and find yourself facing a solidly closed door.

PLAYER: is there anything on the other side?

GAMESMASTER: (With a secret smile) You tell me.

The Player cannot get an answer until his Character has opened the door and looked inside. Then and only then can he ask if he sees the ravening Siberian Tiger waiting there. The traditional "Listening at the Door" ploy which might also be used at this point will succeed or fail according to the Tiger's behavior, the door's construction, and the doctrine of Hidden Things, explained on page 5 of this book. The Gamesmaster will be the one who determines if anything was heard, and if so, what.

Play continues in this form until the session is over. Basically, nothing that is not stated verbally or in writing is assumed to have happened in the campaign. This requires a good deal of honesty and a fair memory on the part of both Players and Gamesmaster. Characters who, moments before, were stated to be holding a flashlight in one hand and turning a doorknob with the other cannot have a gun in their third hand (?) ready to shoot the critter on the other side of that door as soon as it opens (unless they DO have a third hand). On the other hand (fourth hand?), the Gamesmaster must try and note the things the Players are doing that will affect their vision of things, possibly in ways that the Characters are not even aware of. Assumptions in either case can be dangerous and it is really better to ask just what is going on if doubt exists. As the Campaign proceeds, Players and Gamesmasters will tend to evolve their own conventions for calling their actions. Newcomers to a group should be briefed on such conventions, or they will tend to get confused.

THE OTHER GUYS (OR GIRLS)

The "Stars" of the Campaign are, of course, the Player-Characters. They are the bozos out to carve themselves a rep. If they succeed, they will start getting recognition. But not everyone in your Game world is going to be a Player-Character. There are also the NON-Player-Characters, the "Other Guys."

The Gamesmaster plays all the Characters in the Campaign not under Player control. Ideally, he will be able to speak/act "in character" for at least the major members of his "cast." There are several levels of complexity involved with Non-Player-Characters. At the bottom of the list are what we call Extras. These are the non-combatants. When one of them gets in harm's way, he is usually doomed. Next are those we call Rabble. Rabble are slightly more resistant to getting offed than Extras. It is usually not necessary for the Gamesmaster to get too involved with characterizations for these types of Non-Player-Characters, as they do not last long enough to develop well. To be brutally frank, their main purpose is to get killed fighting with Player-Characters, or by valiantly joining them against a common foe.

Other Non-Player-Characters function exactly as do Player-Characters. In general, the better developed such a Character is, the more detail the Gamesmaster will have designed for his personality and background. At the top of the list one finds the "Personality" Non-Player-Characters. These are the big-time operators designed by the Gamesmaster to fill particular niches in a given scenario or the Campaign world in general. This bunch includes the great heroes of the Campaign, the ones who have already achieved the heights the Player-Character are after. Of course, the Personality figures also include the Bad Guys, against whom most Player-Characters will find themselves opposed in the scenarios. (Just reverse certain words in the preceding two sentences if you are dealing with Player-Villains).

But besides other human beings, the Gamesmaster will be simulating the behavior of animals and creatures falling into the twilight zone category of "monsters." In Book 3 we have provided data in the sections cataloging the non-human Characters as to their general personality traits (if any trend exists), special fighting tactics (how is a lion likely to fight in close quarters?) and other general guides. The Gamesmaster should familiarize himself with these.

In general, the same remarks made about Player consistency in portraying their Characters should be observed by the Gamesmaster.

AFTER PLAY

The last section of this article will try and give an overview of the Gamesmaster's job in keeping the Campaign going outside of the actual playing time. The care and feeding of Characters as they increase their abilities, the "Happening World" the Characters live in, the retooling of scenarios in the wake of an invasion by Player-Characters, these will all be touched in the other rulebooks of the set.

KEEPING YOUR BALANCE

Role Playing Games, unlike most other recreations, do not really end. The results of one playing session will permanently affect all subsequent sessions. The main thrust of the Game is biographical, a dramatic creation of the adventurous life of the Player-Character. As Players tackle the really BIG adventures, gaining resources with each one, their actions will start to impact the status of the Campaign as a whole. The Gamesmaster monitors this activity and may exert some control over it as he deems necessary.

For example, on an adventure to some remote place of mystery, a Player-Character finds and retrieves a nearly invincible weapon. Consider: now the Player will not be vulnerable to any challenge resolved by combat. "WOW, Great," says he! After his 50th easy victory of so, both Player and Gamesmaster will note the loss of a certain charm in the Game. It becomes a sure thing, and what before was a gamble in the face of death becomes mindless murder. The killing machine the Character has become mows down all opposition.

No problem, you may think! Just design some special creature that will be on a par with the Character's ability. Then some other poor shmoe runs into the beastie and dies without a chance. Sorta rough.

The above illustration is one of the commoner problems encountered when dealing with Game Balance. As Characters start out in the Campaign, they are not usually equipped with the best they can get. They are not as proficient in their Skills as they might be. They are, in short, easy prey for a really hefty challenge. The early scenarios should reflect this. But as they advance, the Characters will become an altogether tougher proposition and their challenges should increase proportionately. But, there is a point of diminishing returns in all this. Eventually the escalation will either find a new equilibrium (sort of an optimum "Level of heroism") of a type suitable for the Campaign milieu, Or the insane "arms race" will continue, until human capability and valor are incapable of meeting the test. The Gamesmaster must exercise all his judgement and ingenuity to help his Campaign progress smoothly to the fully energized, stable level of heroism, and prevent the runaway development of "invincible" Characters and "unbeatable" Monsters to fight them.

There will always remain certain areas which are not resolvable by unaided human power. But these are the extremes on the scale. The vast bulk of scenarios will deal with things much closer to its center. Like most other potential trouble spots in the group relationships, this can be resolved by talking about it. If the Players feel threatened by the scenario, not because they are in danger (which is the whole idea) but because they feel they cannot win (i.e. survive), it behooves the Gamesmaster to make sure he has built an adventure resolvable by good play, or at least brave play, rather than a pure deathtrap with no option at all.

The exception is the scenario which has been "advertised" as a real stinker. If the Players undertook it knowing it to be very lethal, then second thoughts are no good. One may be sure the Characters are having them too, but it is a little late for that.

IT'S A BIG, WIDE, WONDERFUL WORLD

When you stop to consider it, Player adventurers are very small potatoes as far as most of the inhabitants of the Campaign are concerned. Oh sure, the ones directly concerned are convinced of the importance of all these shenanigans, but what does the larcenous activity of a bunch of avaricious mercenaries have to do with the price of potatoes on market day? Not a great deal.

As your Campaign grows in scope, the events in its history will assume a life of their own, far removed from the events of the scenarios. Nations will go to war (possibly offering employment as soldiers or spies to the Player-Characters. Plagues will ravage certain areas, closing them to free passage. Religious movements, piracy on the coasts, barbarian raids, a multitude of things will testify to the world outside of the adventurer's' experience. Hopefully, they will want to be a part of this "Happening World" and become involved in the pulsing heart of affairs in your world. If not, then do not try to force them into the public eye. Not every Cimmerian is born to be a King!

The nature of the "Happening World" is up to the Gamesmaster and his imagination. Major news from distant places can be a superlative means of signaling to the Players that the territory in question is now available for

travelers and teeming with fresh opportunities for glory and loot. In many cases, you will also need to work out at least a vague history for the Campaign. How else can one explain how things came to be as they are? The more your Campaign encompasses, the greater the need for a vital, living world to hold it, with its own stream of events. The values it can add to the Campaign are incalculable.

HOUSECLEANING

There comes a sad time in every Gamesmaster's career, and usually it is an early experience, when the first adventure set in his carefully constructed Place of Mystery has ended and he must assess the damage. A skillful (or lucky) group of Players can go through the most exquisitely planned labyrinth like army ants, disabling traps, slaying guards, extracting valuables, busting in barriers, scribbling on the walls, littering, you name it.

Now you had figured the Place to be good for half a dozen expeditions, but the shape it is in now, a three-year-old with a slingshot could knock it over. What do you do?

Your options will vary according to your Campaign. If the Place has any sort of residents, with some access to maintenance gear, they could conceivably reset traps and fix doors, move treasure and post new guards. Invaders who rashly re-visit human establishments will usually find things considerably tightened up since their last raid. If the main villain of the scenario avoided death or capture, he will probably abandon the stronghold if it cannot be re-fortified. Surely he will remember the strangers who wiped out his holding! Likewise, loot missed the first time around will probably not be there if all the defenses have been wiped out. There are jackals who follow the tracks of the Player's "lions." Specific details will depend solely on the Gamesmaster's wit and whim. They will often tie in to the "Happenings" described above.

The same philosophy applies to the more public activities of the Player-Characters. Many cultures have laws regarding such lighthearted pastimes as duels to the death, and Players who flout such conventions too often or too openly risk legal sanctions. Again, this is entirely Campaign dependent. Players often seem to forget that the Barbarian societies (so-called) are usually more rigorous in the adherence to custom in such matters than many more civilized ones. Depending on your world's view of such matters, it may be sheer folly for Player-Characters to try and behave in a town the way they would on an expedition. Some fascinating possibilities are inherent in this concept and a wise Gamesmaster will exploit them fully.

L'ENVOI

General discussion of the Gamesmaster's task could go on indefinitely. Put two of this breed down in a corner somewhere to see a convincing example of verbal "perpetual motion." The main precept to remember is this:

You will make errors early on in the Campaign. At times you will have no idea what to do next. It is a big headache of a job. But as things progress, you will find new ideas and fresh insights into the Game process coming to you. It can only get more interesting. It is your world! Go to it.

APPENDIX 1

REACTION TABLE

DIE RESULT (D100)	DESCRIPTION	VALUE NUMBER	NOTES
01-05	Bad	-6	This is a very hostile reaction. It usually indicates the initiation of action if the overall reaction is unfriendly. If the overall reaction is friendly, it tends to indicate a lack of interest in continuing to deal with the Player Characters.
06-15	Very Poor	-4	This is a negative reaction. It can indicate growing hostility.
16-30	Poor	-2	This is a negative reaction. It signals a deteriorating relationship.
31-45	Negative Indifference	-1	An undecided reaction with leanings to the negative.
46-55	Indifference	+0	This reaction indicates no leanings in one direction or the other. In negotiations, it might call for a period to consider the situation.
56-70	Positive Indifference	+1	An undecided reaction with leanings to the positive.
71-85	Good	+2	This is a positive reaction. It can signal an improving relationship.
86-95	Very Good	+4	This is a positive reaction. It indicates growing friendliness and a willingness to agree.
96-00	Excellent	+6	This is a very positive reaction. It tends to indicate willingness and helpfulness. As an initial reaction it may indicate aid is offered freely and before it is requested.

The reaction table is used as a guideline to the reactions of non-player characters whose reactions are not already predicated situation. The Gamesmaster may also use it to give a finer gradation to the reactions of those non-player characters whose general reactions are already assured by the situation.

The descriptions of the results of the die roll are given in general to allow the Gamesmaster the freedom to tailor a response to the particular situation in the game. Due to the nature of dice, a reaction may swing from one end of the spectrum to the other. If the Gamesmaster feels that a particular result is wholly unsuitable, he should feel free to reroll until he gets a result that he feels is appropriate.

In many cases, a roll on the table to give the general tone of the non-player character's reaction to the Player Characters, or to the situation, makes interpretation of later rolls easier. An overall reaction of Excellent will probably not lead to an attack with a result of bad unless the non-player character has in some way been betrayed by the Player Characters.

The Gamesmaster may feel that the situation surrounding an offer should have an effect on the reaction due to its nature. In such cases the Gamesmaster should assign a value to it and add or subtract the value from the die roll to give the result.

In all cases it should be remembered that this table is a guideline only and should not be used slavishly at the expense of good role-playing or the progress of an interesting adventure.

A Gamesmaster can also use the table in another way when he is at a loss for a way to determine a result of a deliberate action or a chance happening. By treating the dice as a sort of oracle, the Gamesmaster may phrase a question which can essentially be answered yes or no. The result of the die roll will indicate a positive or negative response. An indifferent response might require the dice to be rerolled. For example, the Gamesmaster might ask: "Did the character's portable lantern get broken by his fall down the stairs?" A result of "Good" would indicate that it was broken. An "Excellent" result might mean it was smashed beyond repair. A "Poor" result might indicate that it survived the fall but its durability is reduced, while a "Bad" result would mean that it was not even scratched. If the fall was a particularly long one the Gamesmaster might have added the length in meters to the die roll.

APPENDIX 2 Combat Procedure Flowchart

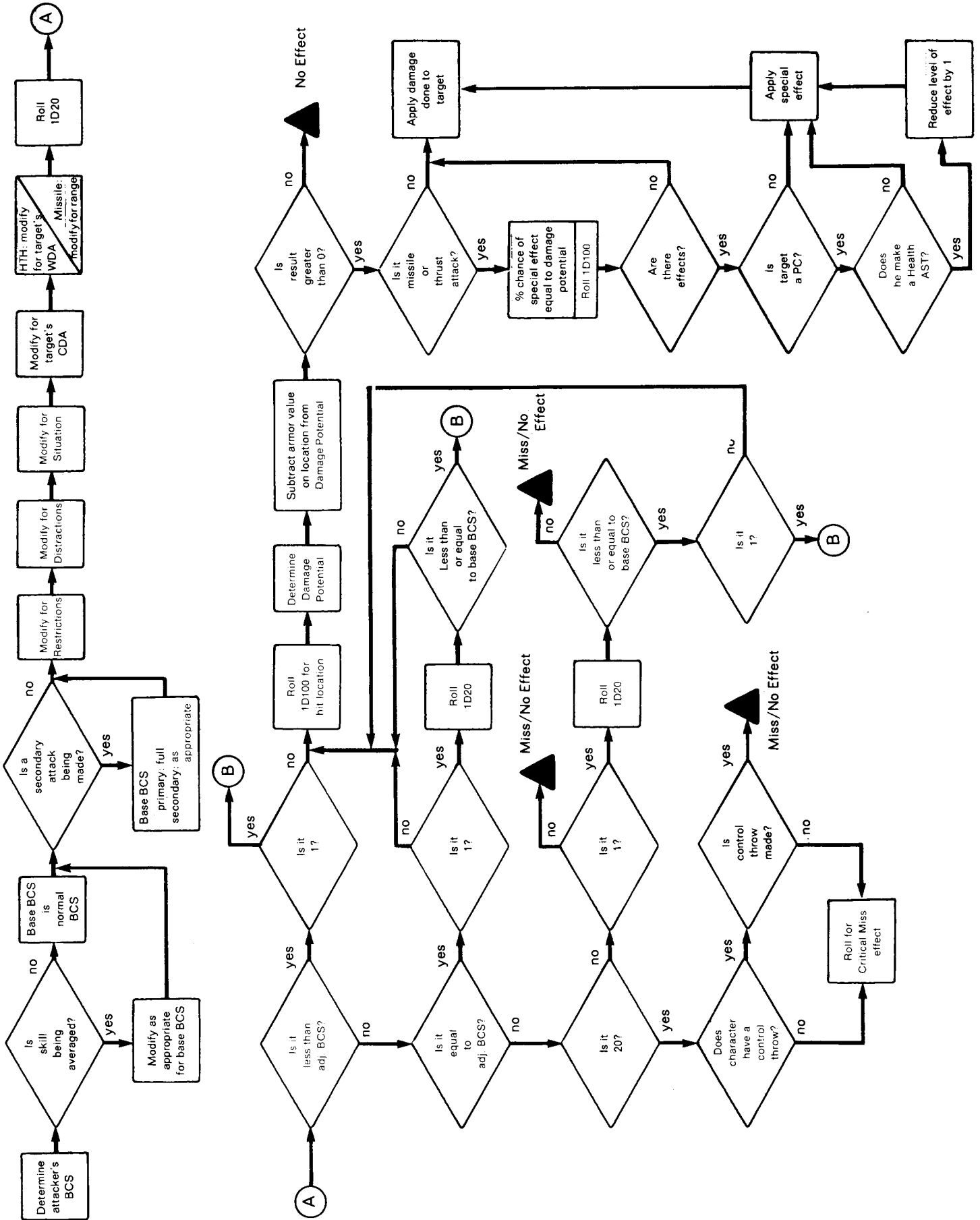

Combat Procedure Flowchart (continued)

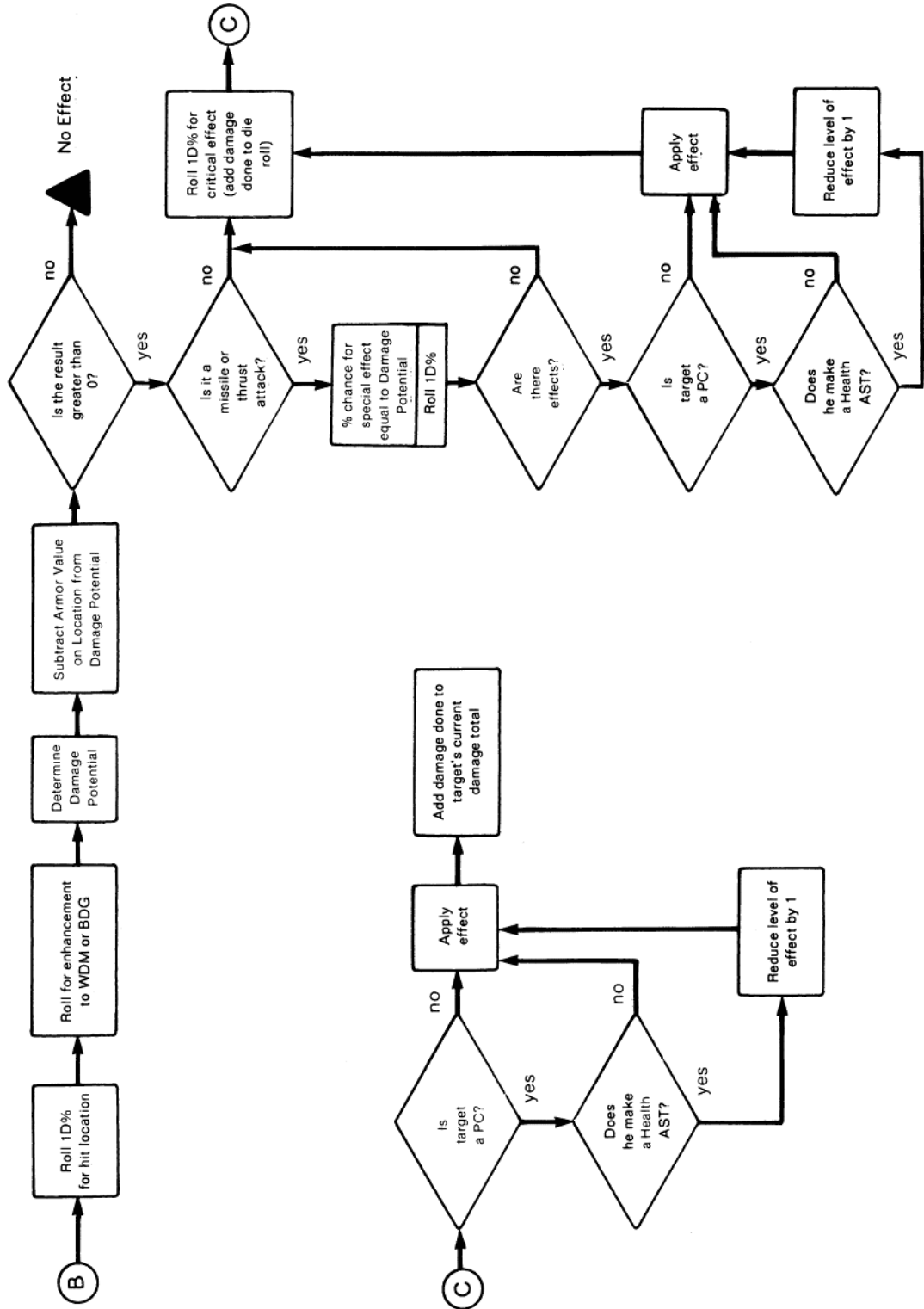

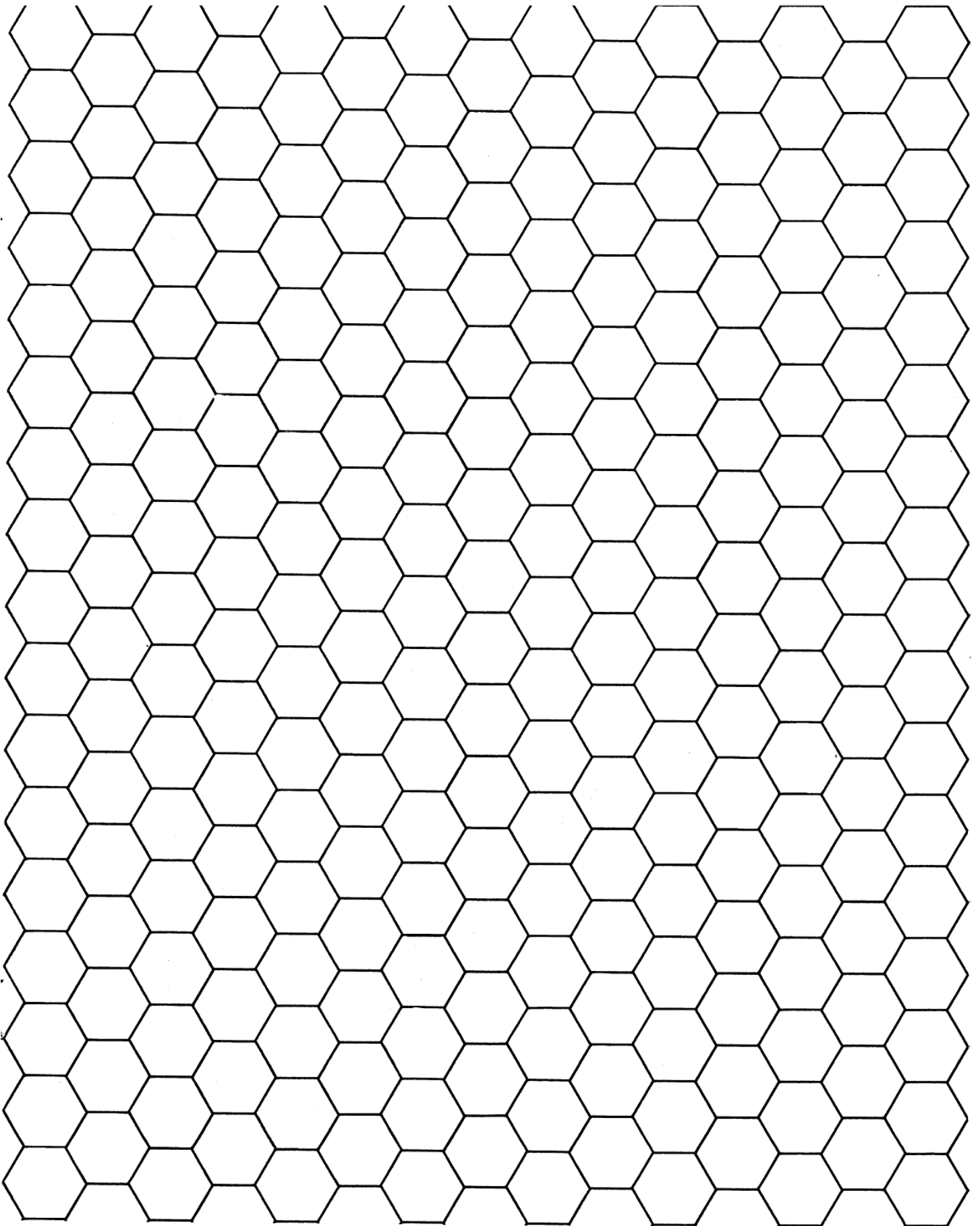

Notice of Permission to photocopy this page